

# Brake

## PB-500 Normal Duty

See page 252 for details on Bushings.

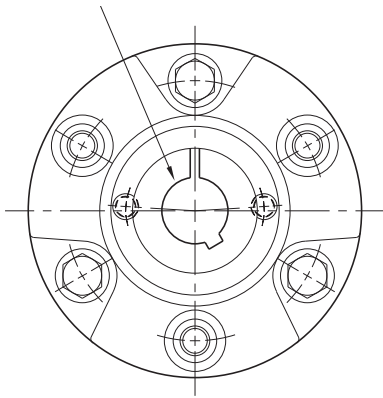

**HUB VIEW**

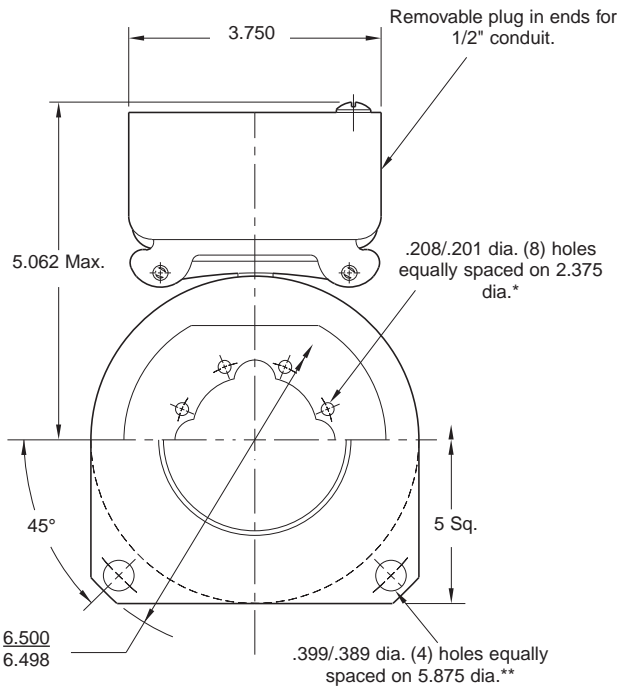
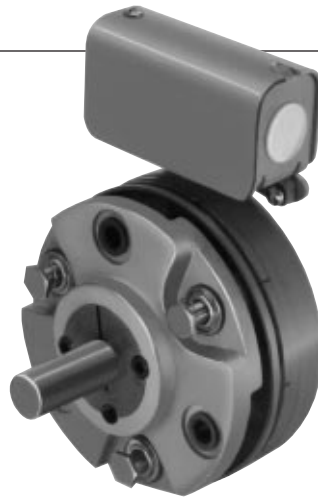

**MAGNET VIEW  
(Inside & Outside Mounted)**

\* Mounting holes are within .010 of true position relative to pilot diameter.

\*\* Mounting holes are within .008 of true position relative to pilot diameter.

**Customer Shall Maintain:**

1. Squareness of brake mounting face with armature hub shaft within .006 T.I.R.
2. Concentricity of brake mounting pilot diameter with armature hub shaft within .010 T.I.R

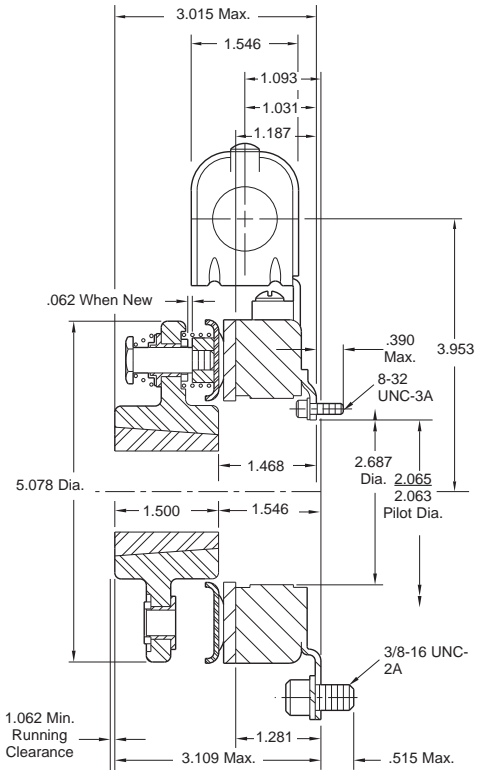

**Outside Mounted Offset Backing Plate**

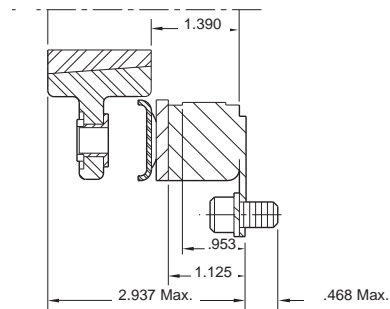

**Outside Mounted Flush Backing Plate**

Static Torque	40 lb.ft.
Maximum Speed	5,400 rpm
Standard Voltage	D.C. 6, 24, 90

All dimensions are nominal unless otherwise noted.

Information on inertia and weights begins on page 239. Coil data is on pages 250 and 251.

Drawing I-25544

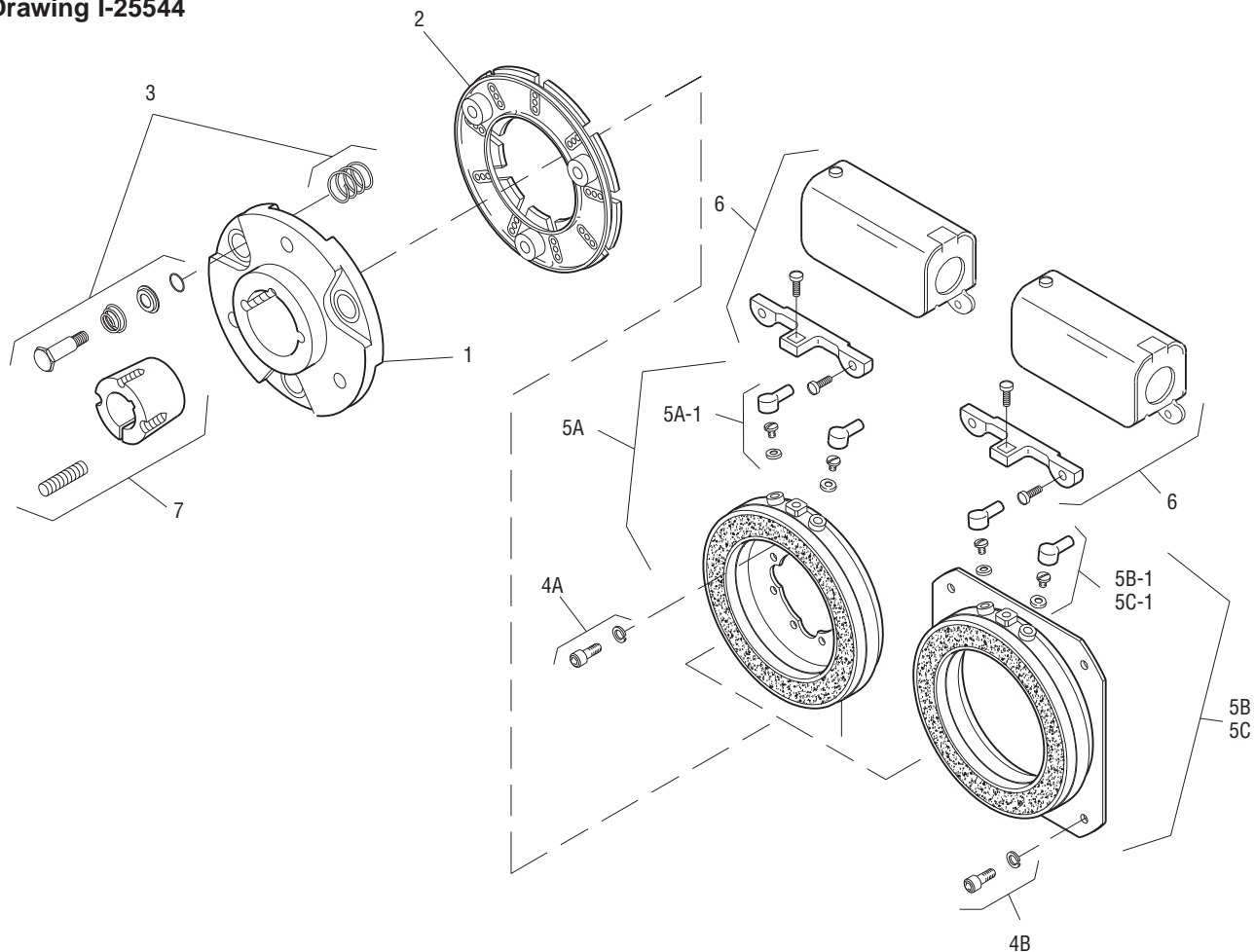

Item	Description	Part Number	Qty.
1	Armature Hub	5300-541-004	1
2	Armature	5300-111-002	1
3	Autogap Accessory	5200-101-009	3
4A	Mounting Accessory - I.M.	5102-101-001	2
4B	Mounting Accessory - O.M.	5300-101-008	1
5A	Magnet - I.M.		1
	6 Volt	5300-631-002	
	24 Volt	5300-631-003	
	90 Volt	5300-631-005	
5A-1	Terminal Accessory	5311-101-001	1
5B	Magnet - O.M. - Offset		1
	90 Volt	5300-631-014	
5B-1	Terminal Accessory	5311-101-001	1
5C	Magnet - O.M. - Flush		1
	6 Volt	5300-631-009	
	24 Volt	5300-631-010	
	90 Volt	5300-631-011	
5C-1	Terminal Accessory	5311-101-001	1
6	Conduit Box	5200-101-010	1

Item	Description	Part Number	Qty.
7	Bushing*		1
	1/2" to 1-1/4" Bore	180-0116 to 180-0128	

### How to Order:

1. Specify Bore Size for Item 7.
2. Specify Voltage for Item 5A, 5B, or 5C.
3. Specify Inside Mounted for Item 5A and Outside Mounted (Offset) for Item 5B or Outside Mounted (Flush) for Item 5C.
4. See Controls Section.

### Example:

PB-500 Brake per I-25544 - 90 Volt, Inside Mounted, 3/4" Bore

These units, when used in conjunction with the correct Warner Electric conduit box, meet the standards of UL508 and are listed under guide card #NMTR, file #59164. These units are CSA certified under file #LR11543.

\*See page 252 for specific part numbers.

Refer to Service Manual P-204.