

# Clutch

## PC-1525 Normal Duty

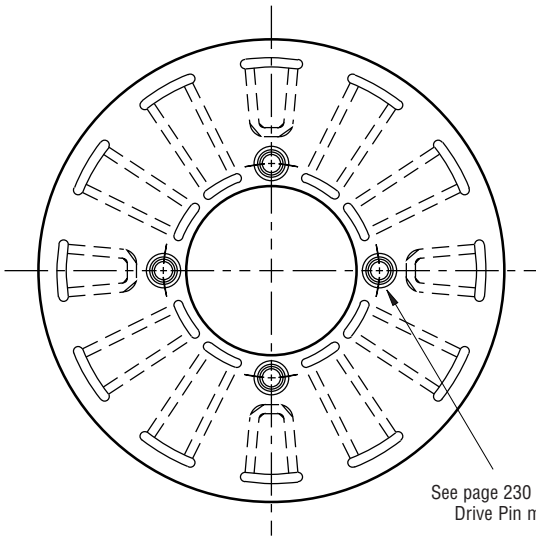

See page 230 for details on Drive Pin mountings.

**ARMATURE VIEW**

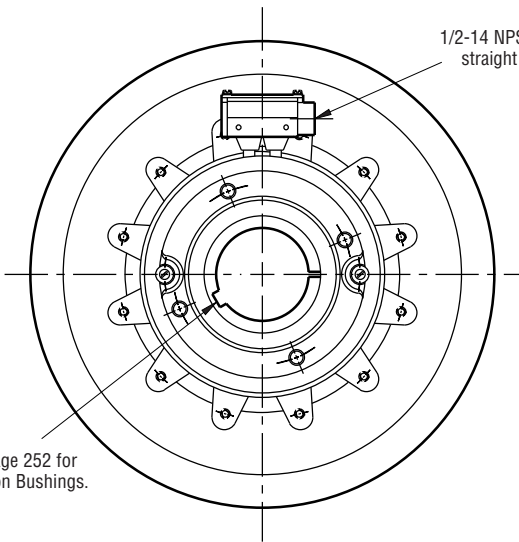

1/2-14 NPSM Am. std. straight pipe tap.

See page 252 for details on Bushings.

**COLLECTOR RING VIEW**

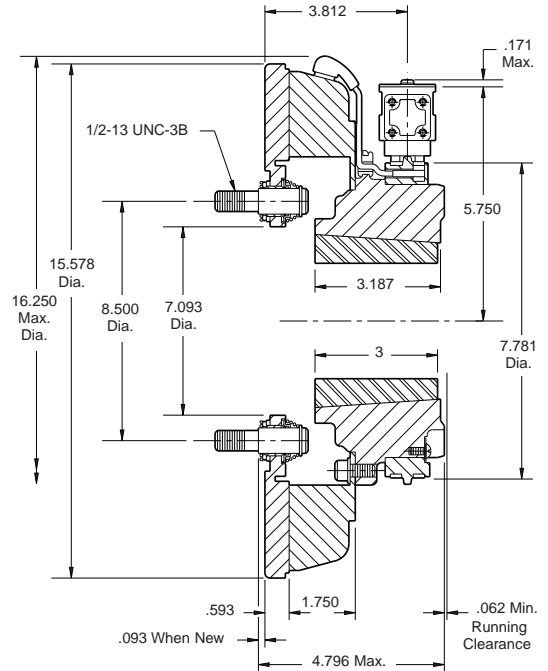

Shaft Size	.937 – 3.000
Static Torque	700 lb.ft.
Maximum Speed	2,000 rpm
Standard Voltage	D.C. 6, 24, 90

All dimensions are nominal unless otherwise noted.

Information on inertia and weights begins on page 239. Coil data is on pages 250 and 251.



Drawing I-25628

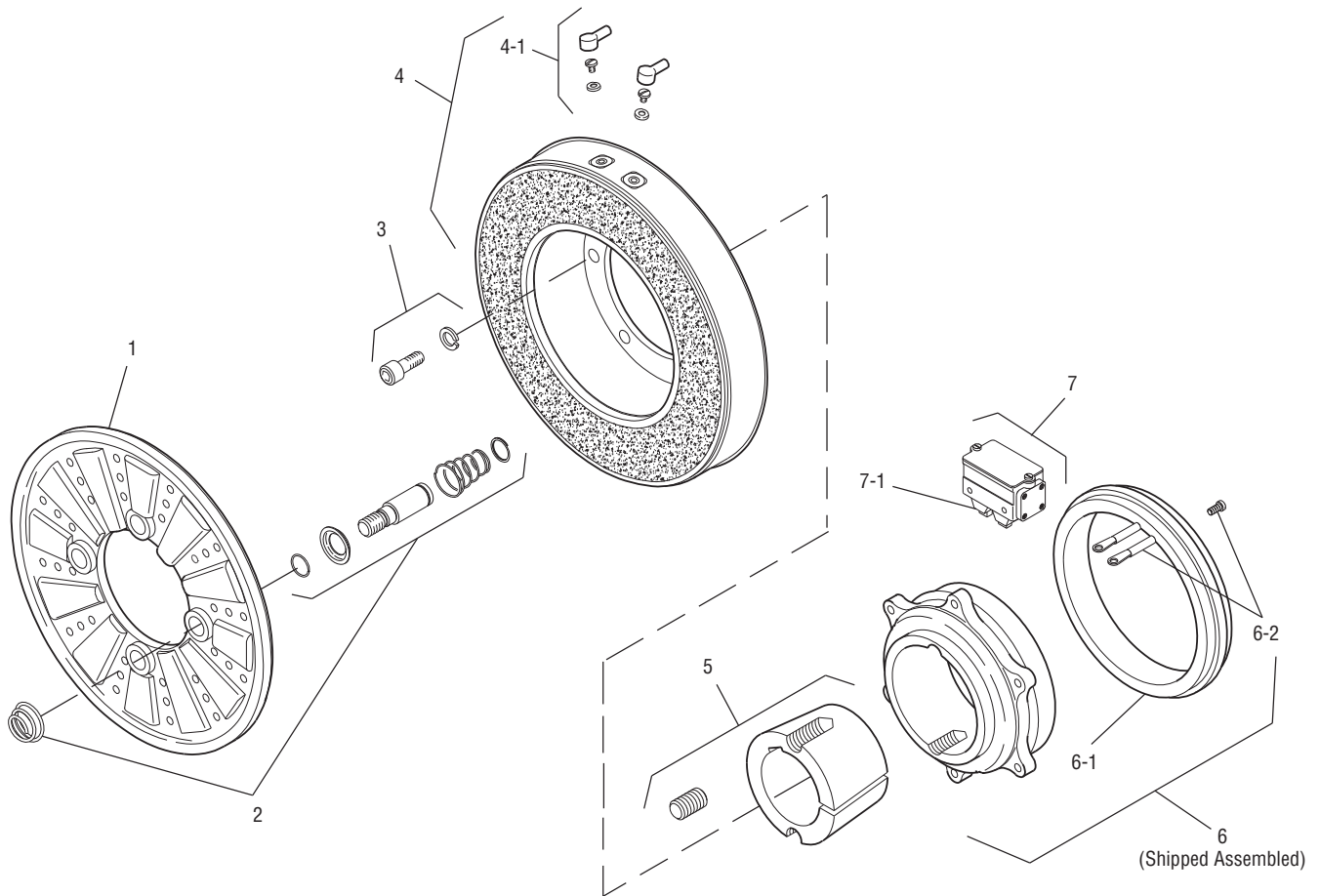

Item	Description	Part Number	Qty.
1	Armature	5304-111-004	1
2	Autogap Accessory	5201-101-008	4
3	Mounting Accessory	5321-101-001	2
4	Magnet		1
	6 Volt	5304-631-009	
	24 Volt	5304-631-011	
	90 Volt	5304-631-010	
	†90 Volt LK Facing	5304-631-002	
4-1	Terminal Accessory	5311-101-001	1
5	Bushing*		1
	15/16" to 3" Bore	180-0262 to 180-0295	
6	Magnet Hub		1
	Left Hand (shown)	5304-541-001	
	Right Hand	5304-541-002	
6-1	Collector Ring	5301-749-001	1
6-2	Collector Ring Accessory	5304-101-004	1

Item	Description	Part Number	Qty.
7	Brushholder	5300-178-001	1
7-1	Brush	176-0001	4

**How to Order:**

1. Specify Voltage for Item 4.
2. Specify Bore Size for Item 5.
3. Specify left hand or right hand hub for Item 6.  
(Bushing enters from magnet side for L.H. hub and from hub side for R.H.)
4. See Controls Section.

**Example:**

PC-1525 Clutch per I-25628 - 90 Volt, L.H. hub, 1" Bore  
 These units meet standards set forth in UL508 and are listed under guide card #NMTR2, file #59164.  
 These units are CSA certified under file #LR11543

\*See page 252 for specific part numbers.

Refer to Service Manual P-206.

†Optional LK facing available. For more information, see page 232.