

**SF-1225 Bearing Mounted**

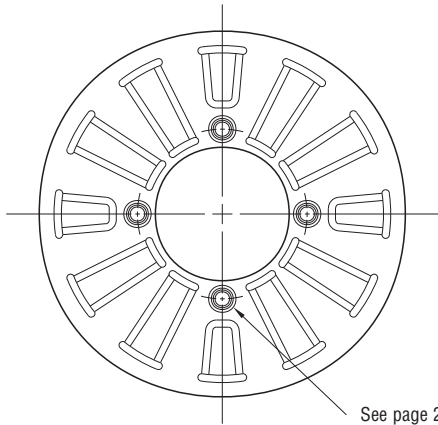

See page 230 for details on Drive Pin mountings.

**ARMATURE VIEW**

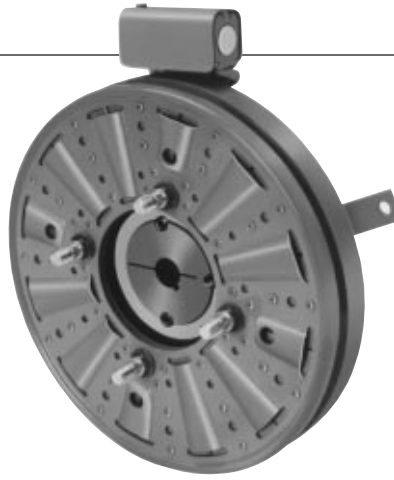
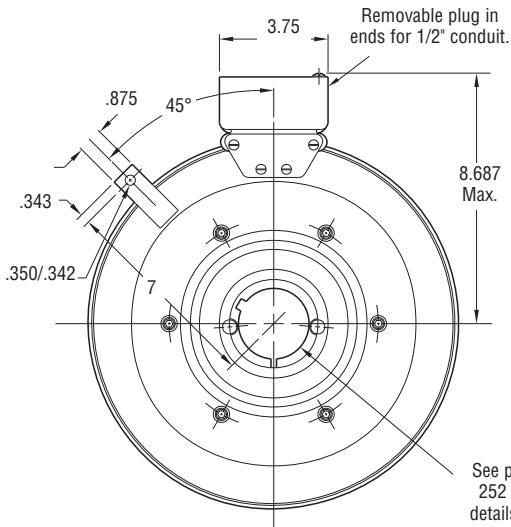

See page 252 for details on Bushings.

**FIELD VIEW**

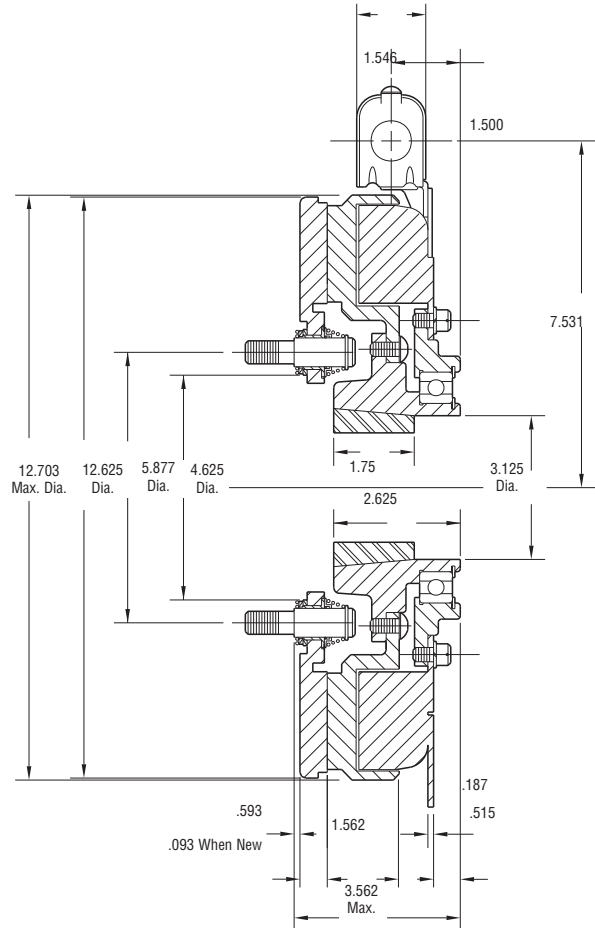

Shaft Size	.500 – 2.500
Static Torque	465 lb.ft.
Maximum Speed	2,200 rpm
Standard Voltage	D.C. 6, 24, 90

All dimensions are nominal unless otherwise noted.

Information on inertia and weights begins on page 239. Coil data is on pages 250 and 251.



Drawing I-25621

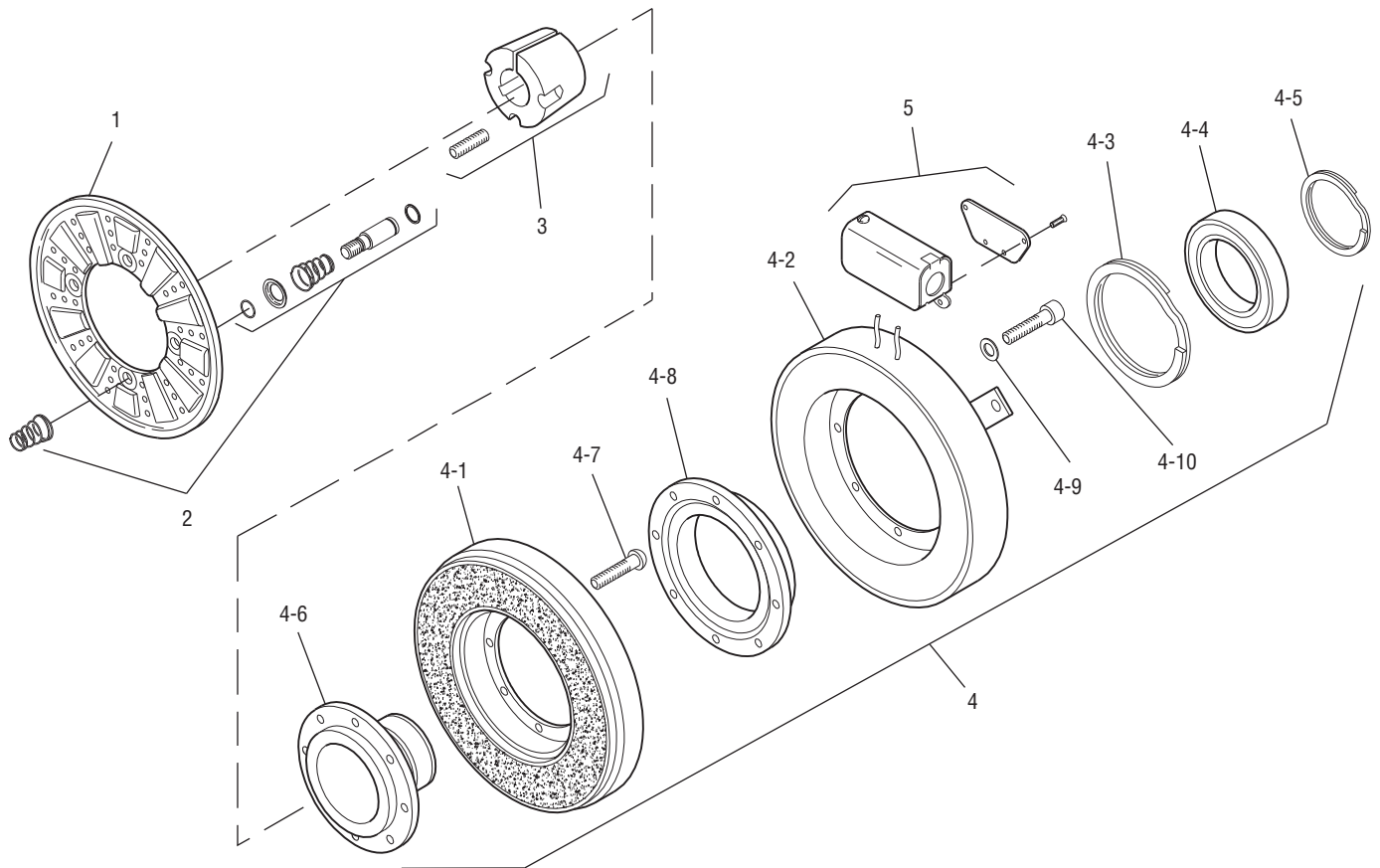

Item	Description	Part Number	Qty.
1	Armature	5303-111-009	1
2	Autogap Accessory	5201-101-008	4
3	Bushing*		1
	1/2" to 2-1/2" Bore	180-0185 to 180-0217	
4	Field and Rotor Assembly		1
	6 Volt	5203-452-009	
	24 Volt	5203-452-011	
	90 Volt	5203-452-012	
4-1	Rotor		1
	Standard Friction Material	5203-751-001	
	†Optional LK Facing	5203-751-004	
4-2	Field		1
	6 Volt	5203-451-034	
	24 Volt	5203-451-036	
	90 Volt	5203-451-037	
4-3	Retainer Ring	748-0119	1
4-4	Ball Bearing	166-1047	1
4-5	Retainer Ring	748-0011	1
4-6	Rotor Hub	540-1304	1

Item	Description	Part Number	Qty.
4-7	Buttonhead Capscrew	797-1261	8
4-8	Ring Adapter	748-0591	1
4-9	Lockwasher	950-0359	6
4-10	Sockethead Capscrew	797-0424	6
5	Conduit Box	5200-101-012	1

### How to Order:

1. Specify Bore Size for Item 3.
2. Specify Voltage for Item 4.
3. See Controls Section.

### Example:

SF-1225 Clutch per I-25621 -  
90 Volt, 1" Bore.

These units, when used in conjunction with the correct Warner Electric conduit box, meet the standards of UL508 and are listed under guide card #NMTR, file #59164. These units are CSA certified under file #LR11543.

\*See page 252 for specific part numbers.

Refer to Service Manual P-215.

†Optional LK facing available. For more information, see page 232.