

Electro-Brake 375, 475, 650, 825, 1000, 1225

P-211
819-0043

Installation Instructions



 **Warner**
Electric

Contents

Installation Instructions	2
Electrical Coil Data	5
Burnishing and Maintenance	6
Illustration Drawings	
EB-375 EB-475 EB-650	8
EB-825	12
EB-1000 EB-1225	14
Bushing Part Number	17
Warranty	Back Page

⚠ WARNING Failure to follow these instructions may result in product damage, equipment damage, and serious or fatal injury to personnel.

Follow the installation instructions in this manual carefully to ensure safe, reliable operation. All stated or implied manufacturer warranties are voided if this product is not installed in accordance with these instructions.

Electro-Brakes

Electro-Brakes may be mounted on either a thru-shaft or a single shaft extension motor. Follow the appropriate instructions for each application.

A. Thru-Shaft Mounting

1. **EB-375.** This unit has a straight bore and mounts directly on a thru-shaft. Slide the unit on the shaft and secure in place by alternately tightening the two set screws in the hub.

Mount **all other EB units** to a thru-shaft with a tapered bushing as follows:

2. Insert a key in the shaft keyway.
3. Place a tapered bushing in the Electro-Brake.
4. Insert the set screws loosely into the bushing,

and slide the brake assembly onto the shaft.

5. Secure the assembly in position by alternately tightening the two setscrews. Tap the bushing lightly from time to time during the tightening process to make certain that it seats in properly. (Figure 1)

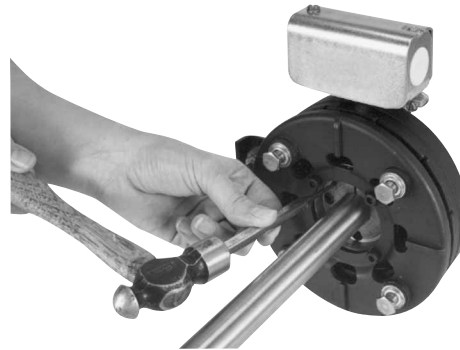

Figure 1

6. Install the torque arm. (See Section C)

B. Motor Mounting

An optional shaft extension is available for mounting all Electro-Brakes, except EB-825, on a single shaft extension motor. (Figure 2)

1. Mount a standard sheave, pulley, or sprocket on section E of the shaft extension with either a tapered bushing or a straight bore.
2. Insert the proper tapered bushing into the Electro-Brake (except EB-375).
3. Assemble the set screws loosely in the bushing.
4. Mount the Electro-Brake on the end of the shaft extension.
5. Mount the complete assembly on the motor shaft and tighten the set screws.
6. Install the belts or chain on the sprocket, pulley, or sheave.
7. Install the torque arm. (See Section C)

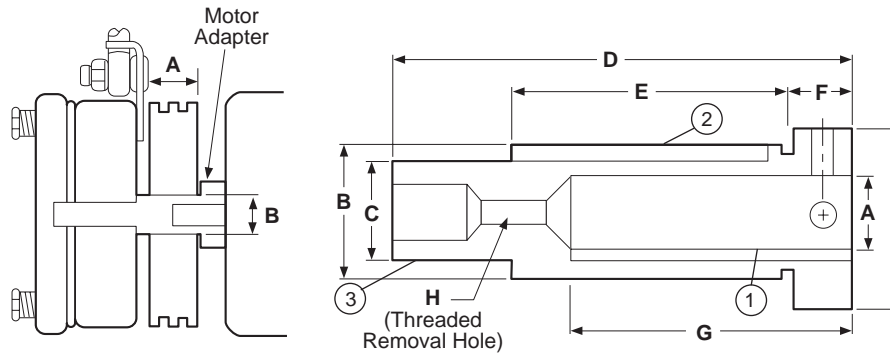

Figure 2

All dimensions are nominal unless otherwise noted.

Model	A	Kwy.	Key Part No. ①	B	Kwy.	Key Part No. ②	C	Kwy.	Key Part No. ③	Dodge Bushing Size	D	E	F	G	H	I
EB-375	5/8	3/16x 3/32	*	7/8	3/16x 3/32	590-0016	5/8	3/16x 3/32	590-0043	None	4.391 4.359	2	.391 .359	2	1/4-20 UNC	1.125
EB-375	7/8	3/16x 3/32	*	1-1/4	1/4x 1/8	590-0022	5/8	3/16x 3/32	590-0043	None	4.578 4.742	2-1/4	.516 .484	2-1/4		1.500
EB-475	1-1/8	1/4x 1/8	*	1-5/8	3/8x 3/16	590-0041	1	1/4x 1/8	**	#1008 1"	4.516 4.484	2-3/4	.641 .609	2-3/4	1/2-13 UNC	1.750
EB-650	1-3/8	5/16x 5/32	*	2	1/2x 1/4	590-0042	1-3/8	5/16x 5/32	590-0044	#1310 1-3/8"	5.547 5.515	3-3/8	.641 .609	3-3/8	1/2-13 UNC	2.125
EB-650	1-5/8	3/8x 3/16	*	2-1/4	1/2x 1/4	590-0042	1-3/8	5/16x 5/32	590-0044	#1310 1-3/8"	6.172 6.140	4	.641 .609	4		2.375
EB-1000	1-5/8	3/8x 3/16	*	2-15/16	3/4x 7/16	590-0052	1-5/8	3/8x 7/32	**	#1615 1-5/8"	8.297 8.265	5-1/4		5	3/4-10 UNC	2.937
EB-1000	1-7/8	1/2x 7/32	*	2-15/16	3/4x 7/16	590-0052	1-5/8	3/8x 7/32	**	#1615 1-5/8"						2.937
EB-1000	2-1/8	1/2x 1/8	590-0062	2-15/16	3/4x 5/16	590-0069	1-5/8	3/8x 7/32	**	#1615 1-5/8"						2.937
EB-1225	2-1/8	1/2x 7/32	*	3-3/4	7/8x 7/16	590-0049	2-1/8	1/2x 9/32	590-0048	#2517 2-1/8"	10.672 10.640	7-1/4		6-7/8	7/8-9 UNC	3.750
EB-1225	2-3/8	5/8x 9/32	*	3-3/4	7/8x 7/16	590-0049	2-1/8	1/2x 9/32	590-0048	#2517 2-1/8"						3.750

*Standard Square Key Furnished with Motor. **Special Key Furnished with Bushing.

C. Installing the Torque Arm

The Electro-Brake magnet is bearing-mounted on the hub and is provided with a torque tab to prevent the magnet from rotating. When the brake is de-energized, the tab need only resist the bearing drag; however when the brake is energized the full braking torque is applied to the tab and restraining mechanism. Since the brake torque is usually substantial, the customary restraining method is to use a rod with a ball joint, as furnished with the Electro-Brake. This

torque arm should be sufficiently long for any normal application and should be mounted so the rod is in tension rather than compression when brake torque is applied. Consult the factory for a recommendation if a longer arm is needed.

The threaded shaft can be cut to any desired length.

EB-375, 475, 650, 825

1. Secure the rod end bearing to the torque arm shaft. (Figure 3)



Figure 3

2. Secure the rod end of the torque arm assembly to the tab on the Electro-Brake.
3. Secure the other end of the torque arm to a base. Refer to Figure 6 to determine the correct position for securing the tab and torque arm. Although the arm may be mounted in either direction, installing it as illustrated is important to good bearing life.

EB-1000, 1225

4. Assemble the ball joints to both ends of the threaded shaft. At least one inch of the shaft must be threaded into each ball joint. (Figure 4)



Figure 4

5. Secure the torque arm to the brake so that the ball joint is inside the tab and the jam nut is on the outside (Figure 5). Rotate the ball joint to facilitate this operation. Simply loosen the jam nut on the shaft, and reposition the jam nut to the desired position. Retighten the jam nut to 90-95 ft. lbs. torque.



Figure 5

6. Secure the other end of the torque arm to a base. Refer to Figure 6 to determine the correct position for securing the tab and torque arm. Although the arm may be mounted in either direction, the bracket must be parallel to the torque rod.

D. Electrical Installation

A wiring diagram showing the electrical connections that must be made is furnished with each Warner Electric control. Service Manual P-239 includes complete information on all standard power supplies.

E. Wearing Parts

The magnet and armature, the two main wearing parts, wear at nearly the same rate. When these parts are worn out, Warner Electric recommends that the entire brake be replaced.

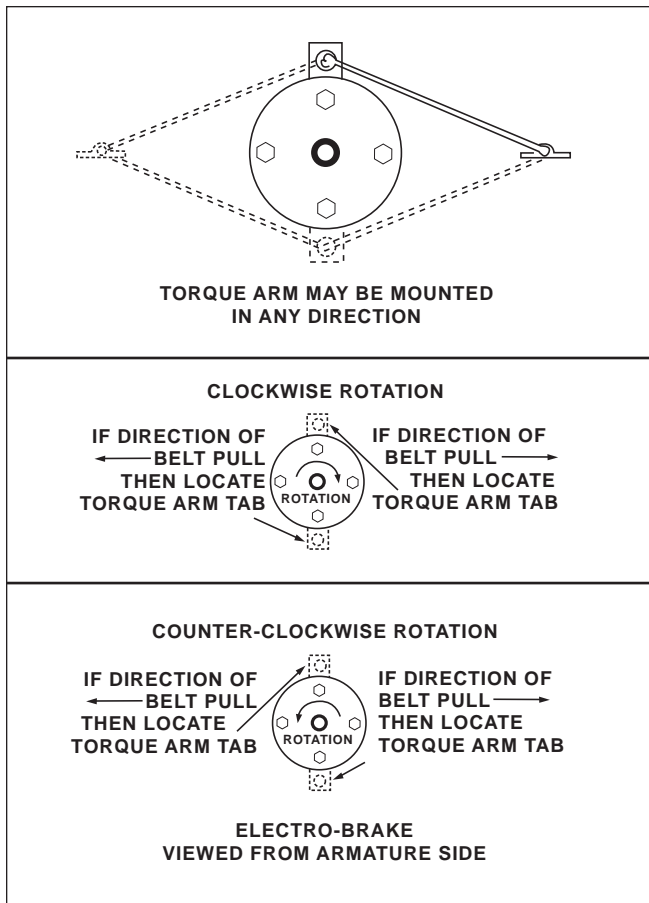

Figure 6

Electrical Coil Data

EC/EB-375	EC	EC	EB	EB
Voltage — DC	90	6	90	6
Resistance @ 20°C — Ohms	453.5	2.10	446.8	1.96
Current — Amperes	.198	2.85	.201	3.07
Watts	17	17	18	18
Coil Build-up — Milliseconds	62	59	50	52
Coil Decay — Milliseconds	13	15	8	10

EC/EB-475	EC	EC	EB	EB
Voltage — DC	90	6	90	6
Resistance @ 20°C — Ohms	368.9	2.32	443.1	2.05
Current — Amperes	.244	2.58	.203	2.93
Watts	22	16	18	18
Coil Build-up — Milliseconds	92	90	80	70
Coil Decay — Milliseconds	18	16	8	9

EC/EB-650	EC	EC	EB	EB
Voltage — DC	90	6	90	6
Resistance @ 20°C — Ohms	225	1.16	257.2	1.24
Current — Amperes	.4	5.19	.35	4.84
Watts	36	31	32	29
Coil Build-up — Milliseconds	120	110	112	105
Coil Decay — Milliseconds	20	20	12	14

EC/EB-825	EC	EC	EB	EB
Voltage — DC	90	6	90	6
Resistance @ 20°C — Ohms	221	1.098	223.3	1.27
Current — Amperes	407	5.464	.4	4.74
Watts	37	33	36	28
Coil Build-up — Milliseconds	225	180	170	170
Coil Decay — Milliseconds	130	115	80	70

EC/EB-1000	EC	EC	EB	EB
Voltage — DC	90	6	90	6
Resistance @ 20°C — Ohms	248.7	1.23	248.7	1.23
Current — Amperes	.36	4.87	.36	4.87
Watts	33	29	33	29
Coil Build-up — Milliseconds	250	220	235	205
Coil Decay — Milliseconds	70	80	70	80

EC/EB-1225	EC	EC	EB	EB
Voltage — DC	90	6	90	6
Resistance @ 20°C — Ohms	207.3	1.04	261.7	1.33
Current — Amperes	.43	5.79	.34	4.5
Watts	39	35	31	27
Coil Build-up — Milliseconds	500	480	460	435
Coil Decay — Milliseconds	220	240	190	140

Burnishing and Maintenance

Burnishing

Intimate metal to metal contact is essential between the armature and the metal rings (poles) of the magnet or rotor. Warner Electric clutches and brakes leave the factory with the friction material slightly undercut to assure good initial contact.

Normally, the desired wearing-in process occurs naturally as the surfaces slip upon engagement. The time for wear-in, which is necessary to obtain the ultimate torque of the unit, will vary depending on speed, load, or cycle duty.

If maximum torque is required immediately after installation, the unit should be burnished by slipping the friction surfaces together at reduced voltage. It is recommended that the burnishings be done right on the application, if at all possible.

Burnishing at high speed will result in a smoother wear-in pattern and reduce the time for burnishing. The voltage should be set at approximately 30% or 40% of the rated value.

The unit should be cycled on and off to allow sufficient time between slip cycles to prevent overheating.

When a Warner Electric brake or clutch is properly assembled and installed, no further servicing, lubrication, or maintenance should be required throughout the life of the unit.

Maintenance

Wear Pattern: Wear grooves appear on the armature and magnet surfaces. This is a normal wear condition, and does not impair functioning of the unit. Normally, the magnet and armature, as a mating pair, will wear at the same rate. It is the usual recommendation that both components be replaced at the same time.

Re-machining the face of a worn armature is not recommended. If a replacement armature is to be used with a used magnet, it is necessary to re-machine the worn magnet face. In refacing a magnet: (1) machine only enough material to clean up the complete face of the magnet; (2) hold the face within .005" of parallel with the mounting plate; and (3) undercut the molded facing material .001" - .003" below the metal poles.

Heat: Excessive heat and high operating temperatures are causes of rapid wear. Units, therefore, should be ventilated as efficiently as possible, especially if the application requires fast, repetitive cycle operation.

Foreign Materials: If units are used on machinery where fine, abrasive dust, chips or grit are dispelled into the atmosphere, shielding of the brake may be necessary if maximum life is to be obtained.

Where units are used near gear boxes or transmissions requiring frequent lubrication, means should be provided to protect the friction surfaces from oil and grease to prevent serious loss of torque.

Oil and grease accidentally reaching the friction surfaces may be removed by wiping with a rag dampened with a suitable cleaner, which leaves no residue. In performing this operation, do not drench the friction material.

If the friction materials have been saturated with oil or grease, no amount of cleaning will be completely effective. Once such a unit has been placed back in service, heat will cause the oil to boil to the surface, resulting in further torque loss.

Torque Loss: If a brake or clutch slips or loses torque completely, the initial check should be the input voltage to the magnet as follows:

90-Volt Series: Connect a DC voltmeter with a range of 0-100 or more directly across the magnet terminals. With the power on and the poten-

tiometer turned up, a normal reading is 90 volts, although 85 to 95 is satisfactory. The reading should drop as the potentiometer control is adjusted counterclockwise.

24-Volt Series: Use a DC voltmeter with a range of 0-30 volts or more. A normal reading is approximately 22-26 volts.

6-Volt Series: Use a DC voltmeter of approximately 0-15 volt range. A normal reading is from 5.5 to 6.5 volts.

The above checks normally are sufficient. Further checks may be made as follows: a low range ammeter, when connected in series with one magnet lead, will normally indicate approximately .40 amperes for the 90 volt units, 1.0 ampere for the 24 volt, and 3.5 amperes for the 6 volt series. These readings are with the power on and the potentiometer control in the maximum position.

Ohmmeter checks should be made with the power off and the circuit open (to be certain, disconnect one lead to the magnet). Average resistance for the 90 volt series is 220 ohms; for the 24 volt, 20 ohms; and for the 6 volt series, 1.5 ohms. A very high or infinite resistance reading would indicate an open coil.

If the above checks indicate that the proper voltage and current is being supplied to the magnet, mechanical parts should be checked to assure that they are in good operating condition and properly installed.

EB-375, EB-475, EB-650

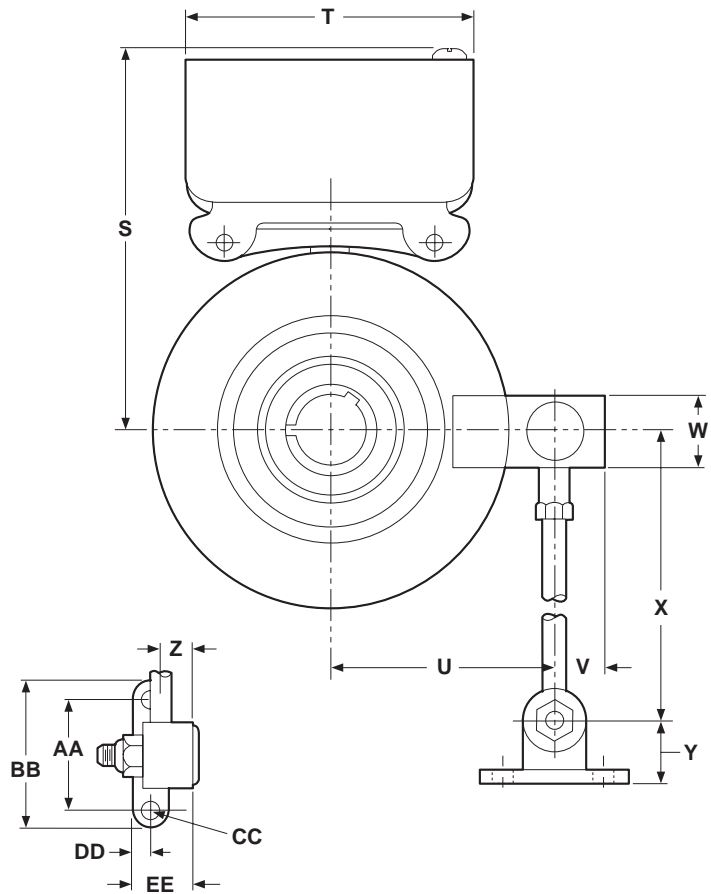
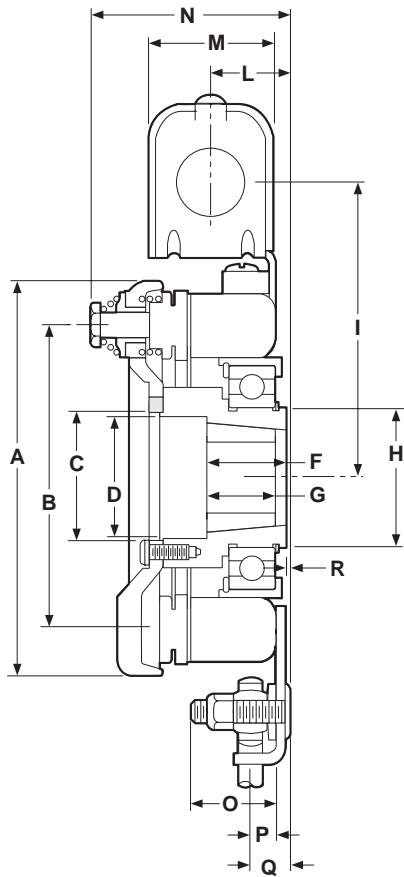

Adapter Requirements

For thru-shaft mounting, specify bore size. For EB-475 and EB-650 order bushing separately. EB-375 does not require a bushing.

For motor mounting, order adapter separate (see page 4).

Bore Sizes and Keyway

Size	Bore Dia.	Keyway
375	.626/.625	3/16 x 3/32
	.501/.500	1/8 x 1/16
475	.500/.563	1/8 x 1/16
	.625/.875	3/16 x 3/32
	.938/1.000	*1/4 x 1/8
650	.500/.563	1/8 x 1/16
	.625/.875	3/16 x 3/32
	1.250/1.313	1/4 x 1/8
	1.313/1.375	5/16 x 5/32

*Key Furnished

EB-375, EB-475, EB-650

All dimensions are nominal, unless otherwise noted.

Size	A Max.	B Dia.	C Min.	D Dia.	E	F	G	H Dia.	I	J	K	L	M	N Max.	O
375	4.078	3.125	.7505	–	.031	1.656	–	1.375	3.344	10-32 UNF -3A x 1/4	.188	1.047	1.547	2.438	.844
475	5.172	4.000	1.663	1.594	–	1.000	1.000	1.781	3.875	–	–	3.031	1.547	2.922	1.094
650	6.578	5.125	2.343	2.281	–	1.313	1.000	2.563	4.656	–	–	3.031	1.547	3.109	1.031

Size	P	Q	R	S Max.	T	U	V	W	X	Y	Z	AA	BB	CC	DD	EE
375	.281	.625	.094 Min.	4.453	3.750	2.453	.656	1.000	8.000	.781	.359	1.500	2.000	.270 .260	.250	.781
475	.313	.531	.125 Max.	4.984	3.750	3.094	.781	1.000	10.000	.688	.391	1.500	2.000	.270 .260	.250	.781
650	.344	.641	.203 Max.	5.766	3.750	4.063	.781	1.125	11.000	.844	.438	1.500	2.000	.270 .260	.250	.781

Specifications

Model Size	Voltage DC	Static Torque (lb. ft.)	Max. Speed RPM	Inertia-WR ² (lb. ft ²)		Total Weight lbs.
				Arm. & Carrier	Hub	
EB-375	6, 24, 90	16	5000	.010	.001	4
EB-475	6, 24, 90	30	4500	.072	.006	7
EB-650	6, 24, 90	95	3600	.106	.010	11.3

EB-375, EB-475, EB-650

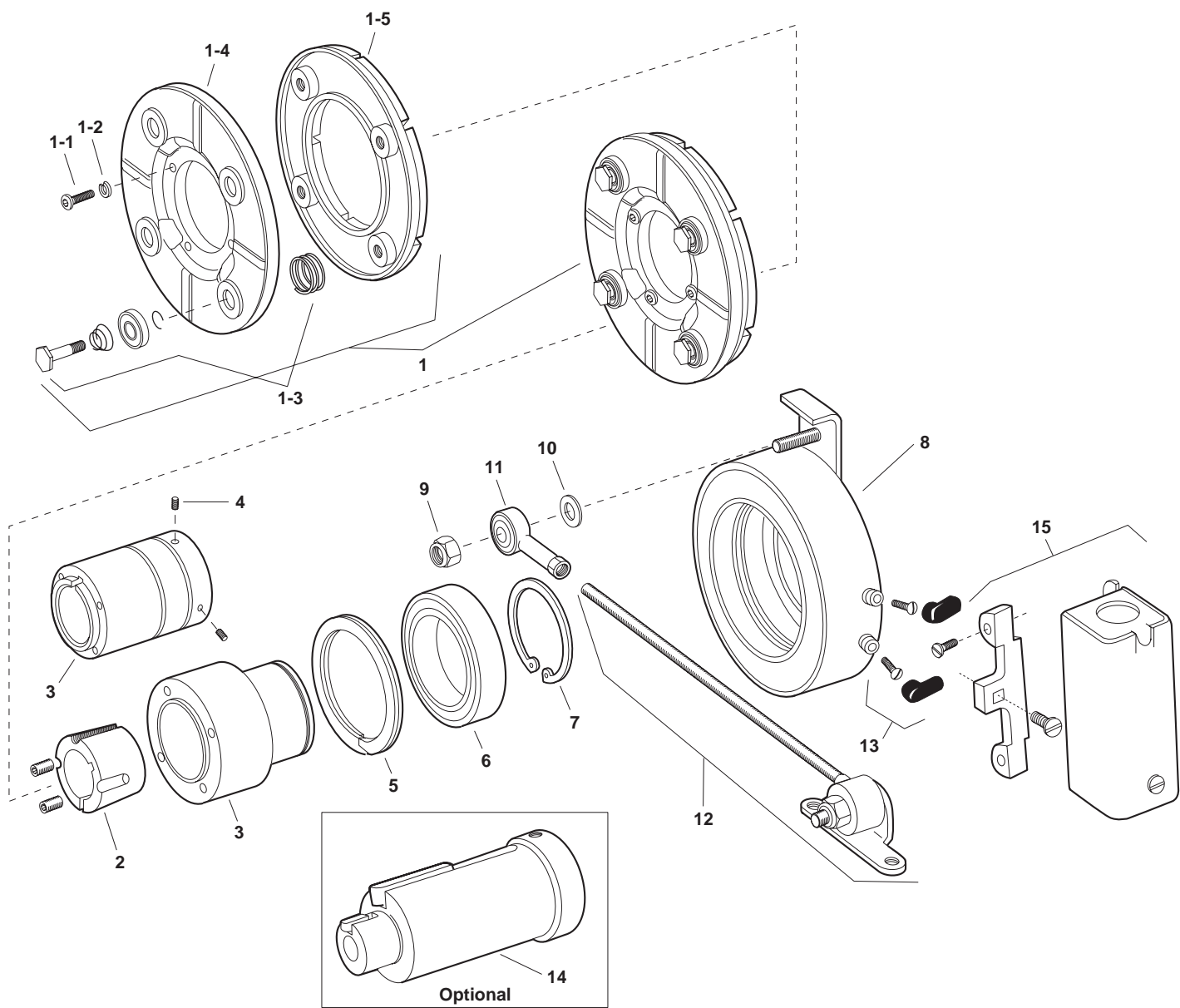

EB-375, EB-475, EB-650

Component Parts

Item	Description	EB-375		EB-475		EB-650	
		Part No.	Qty.	Part No.	Qty.	Part No.	Qty.
1	Armature & Carrier Assembly	5380-101-006	1	5381-101-004	1	5382-101-005	1
	1-1 Capscrew	797-1214	3	797-1214	4	797-0086	4
	1-2 Lockwasher	950-0102	3	950-0102	4	950-0103	4
	1-3 Autogap Accessory	5180-101-011	3	5181-101-010	4	5181-101-010	4
	1-4 Carrier	5380-295-002	1	5381-295-003	1	5382-295-002	1
	1-5 Armature	5180-111-002	1	5181-111-002	1	5281-111-002	1
2	*Bushing			180-0410-180-0418 1/2" to 1" bore	1	180-0421-180-0435 1/2" to 1-3/8" bore	1
3	Hub		1	540-0524	1	540-0523	1
	1/2" Bore	540-0520					
	5/8" Bore	540-0519					
4	Set Screw		2				
	1/2" Bore	797-0368					
	5/8" Bore	797-0366					
5	Retainer Ring	748-0101	1	748-0102	1	748-0104	1
6	Ball Bearing	166-0150	1	166-0110	1	166-0104	1
7	Retainer Ring	748-0018	1	748-0002	1	748-0004	1
8	Magnet		1		1		1
	6 volt	5380-631-003		5381-631-003		5382-631-003	
	24 volt	5380-631-004		5381-631-004		5382-631-005	
	90 volt	5380-631-002		5381-631-002		5382-631-002	
9	Locknut	661-0050	1	661-0051	1	661-0004	1
10	Washer	950-0029	1	950-0026	1	950-0030	1
11	Rod End Bearing	166-0186	1	166-0187	1	166-0188	1
12	Torque Arm Rod Assembly	5380-112-001	1	5381-112-001	1	5382-112-001	1
13	Terminal Accessory	5311-101-001	1	5311-101-001	1	5311-101-001	1
14	Adapter (optional)		1		1		1
	5/8" Motor Shaft	5380-101-005					
	7/8" Motor Shaft	5380-101-004					
	1-1/8" Motor Shaft			5381-101-003			
	1-3/8" Motor Shaft					5382-101-003	
	1-5/8" Motor Shaft					5382-101-002	
15	Conduit Box	5200-101-010	1	5200-101-010	1	5200-101-010	1

*See page 20 for specific part numbers.

These units when used with the correct Warner Electric conduit box, meets the standards of UL508 and are listed under guide care #NMTR, file #59164. These units are CSA Certified under file #LR11543.

EB-825

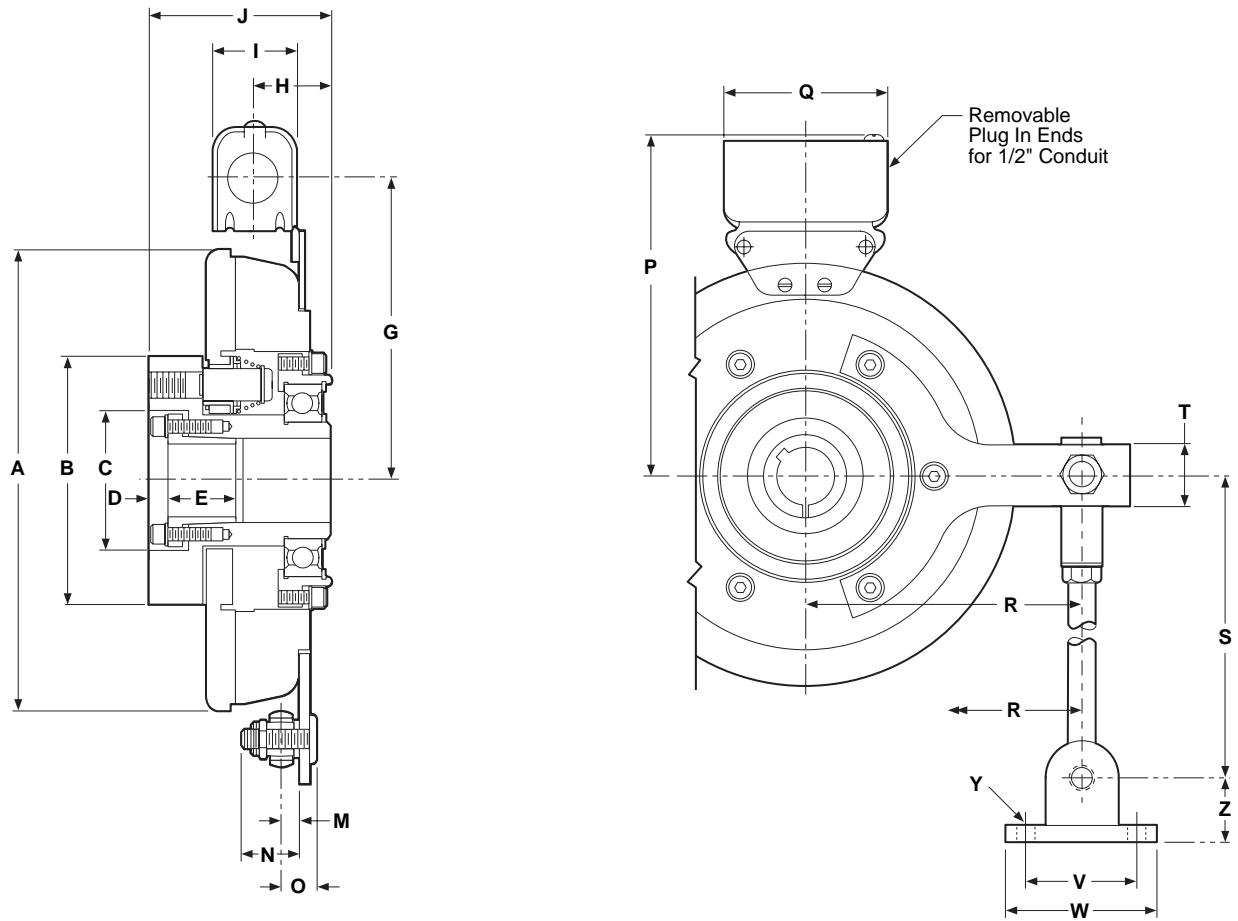

Size	A Max.	B Max.	C Dia.	D	E	F	G	H	I	J Max.	K	L	M
825	8.656	4.625	2.625	.563	1.250	-	5.641	1.344	1.547	3.375	-	-	.344

Size	N	O	P Max.	Q	R	S	T	U	V	W	X	Y	Z
825	1.031	.641	6.813	3.750	4.813	11.000	1.125	-	1.500	2.000	-	.270 .260	.781

Specifications

Model Size	Voltage DC	Static Torque lb. ft.	Max. Speed RPM	Inertia-WR ² (lb. ft ²) Arm. & Hub	Total Weight lbs.
EB-825	6, 24, 90	125	3600	.459	20

EB-825

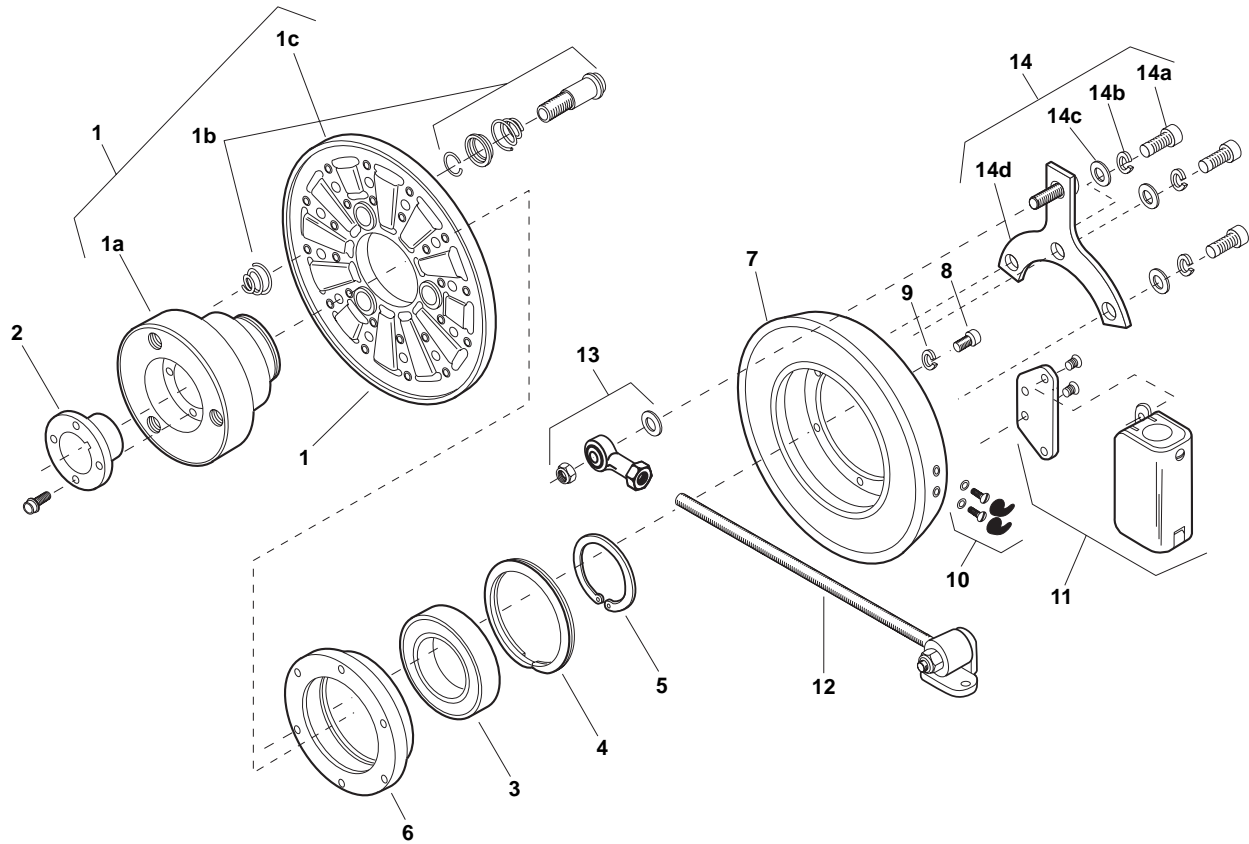

Component Parts

EB-825			
Item	Description	Part No.	Qty.
1	Armature Assembly	5383-111-001	1
	1a Hub	540-1299	1
	1b Autogap Assembly	5201-101-008	3
	1c Armature	5282-111-001	1
2	*Bushing	180-0002 to 180-0018 1/2" to 1-1/2" Bore	1
3	Ball Bearing	166-0168	1
4	Retainer Ring	748-0120	1
5	Retainer Ring	748-0584	1
6	Adapter Ring	748-0631	1
7	Magnet Assembly		1
	6 volt	5383-631-002	
	24 volt	5383-631-004	
	90 volt	5383-631-005	

EB-825			
Item	Description	Part No.	Qty.
8	Capscrew	797-0079	3
9	Lockwasher	950-0372	6
10	Terminal Accessory	5311-101-001	1
11	Conduit Box	5200-101-011	1
12	Torque Arm Rod Assembly	5382-112-001	1
13	Rod End Assembly	5382-101-007	1
14	Torque Arm Kit	5383-101-001	1
14a	Screw	797-0077	3
14b	Lock Washer	950-0372	3
14c	Flat Washer	801-1049	3
14d	Torque Arm	5383-112-001	1

*See page 20 for specific part numbers.

These units when used with the correct Warner Electric conduit box, meets the standards of UL508 and are listed under guide care #NMTR, file #59164.

EB-1000, EB-1225

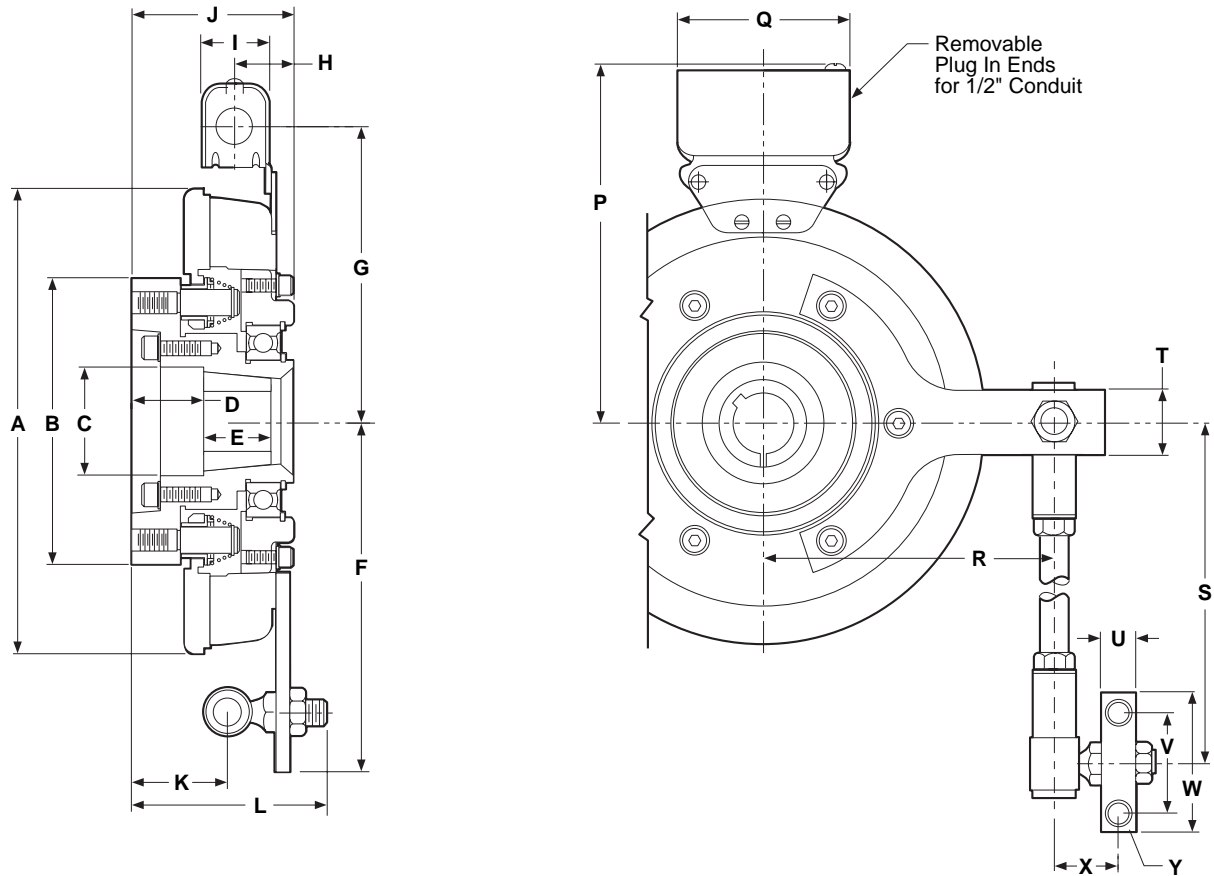

Adapter Requirements

For thru-shaft mounting, specify bore size. Order bushing separately.

For motor mounting order adapter separate (see page 4).

Size	A Max.	B Max.	C Dia.	D	E	F	G	H	I	J Max.	K	L	M
1000	10.328	6.344	2.563	1.563	1.500	7.688	6.531	1.281	1.547	3.531	2.266	4.531	-
1225	12.672	6.969	3.391	.875	1.750	8.438	7.531	1.297	1.547	3.719	2.453	4.703	-

Size	N	O	P Max.	Q	R	S	T	U	V	W	X	Y	Z
1000	-	-	7.688	3.750	-	18.000	1.500	.750	.2375	3.375	1.438	.413 .404	-
1225	-	-	8.688	3.750	-	18.000	1.500	.750	2.375	3.375	1.438	.413 .404	-

Specifications

Model Size	Voltage DC	Static Torque lb. ft.	Max. Speed RPM	Inertia-WR ² (lb. ft ²)		
				Arm. & Hub	Hub	Total Weight lbs.
EB-1000	6, 24, 90	240	2000	.720	.129	35.5
EB-1225	6, 24, 90	465	2000	1.8	.129	52.5

EB-1000, EB-1225

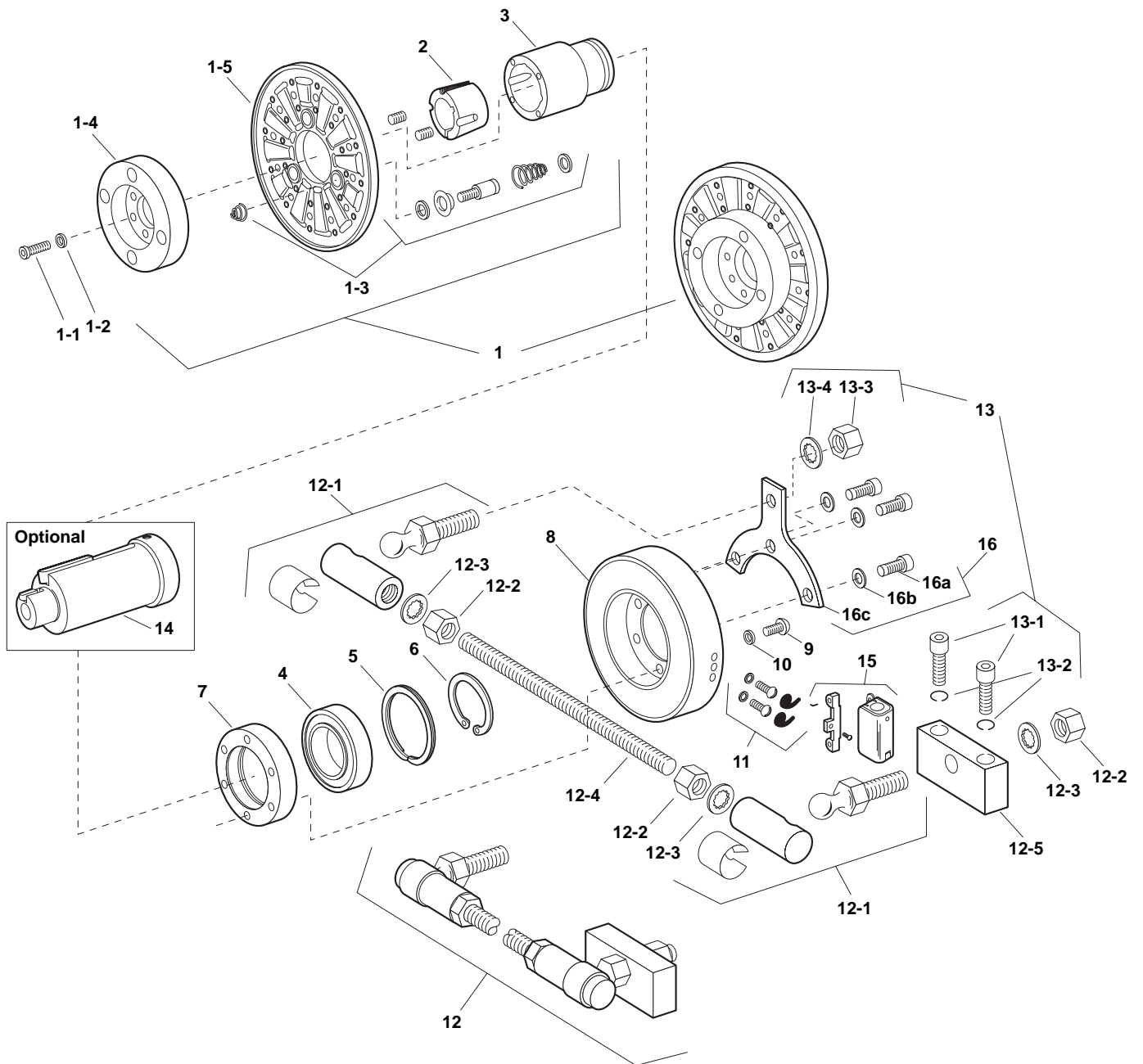

EB-1000, EB-1225

Component Parts

Item	Description	EB-1000		EB-1225	
		Part No.	Qty.	Part No.	Qty.
1	Armature & Carrier Assembly	5384-111-003	1	5385-111-004	1
	1-1 Capscrew	797-1163	6	797-1163	8
	1-2 Lockwasher	950-0111	6	950-0111	8
	1-3 Autogap Accessory	5201-101-008	3	5201-101-008	4
	1-4 Hub	540-1339	1	540-1341	1
	1-5 Armature	5302-111-013	1	5385-111-003	1
2	*Bushing	180-0131-180-0149		180-0185-180-0217	
		1/2" to 1-5/8" bore	1	1/2" to 2-1/2" bore	1
3	Hub	540-0579	1	540-0578	1
4	Ball Bearing	166-0164	1	166-0163	1
5	Retainer Ring	748-0116	1	748-0114	1
6	Retiner Ring	748-0501	1	748-0074	1
7	Adapter Ring	748-0467	1	748-0465	1
8	Magnet Assembly		1		1
	6 volt	5384-631-002		5385-631-002	
	24 volt	5384-631-009		5385-631-009	
	90 volt	5384-631-003		5385-631-003	
9	Capscrew	797-0416	3	797-0416	3
10	Lockwasher	950-0355	3	950-0355	3
11	Terminal Accessory	5311-101-001	1	5311-101-001	1
12	Torque Arm Rod Assembly	5385-757-001	1	5385-757-001	1
	12-1 Ball Joint	585-0001	2	585-0001	2
	12-2 Jam Nut	661-0012	3	661-0012	3
	12-3 Lockwasher	950-0114	3	950-0114	3
	12-4 Threaded Rod	756-0030	1	756-0030	1
	12-5 Bracket	174-0073	1	174-0073	1
13	Torque Arm Mounting Accessory	5385-101-001	1	5385-101-001	1
	13-1 Capscrew	797-0293	2	797-0293	2
	13-2 Lockwasher	950-0354	2	950-0354	2
	13-3 Jam Nut	661-0012	1	661-0012	1
	13-4 Lockwasher	950-0114	1	950-0114	1
14	Adapter (optional)		1		1
	1-5/8" Motor Shaft	5384-101-008			
	1-7/8" Motor Shaft	5384-101-007			
	2-1/8" Motor Shaft	5384-101-010		5385-101-008	
	2-3/8" Motor Shaft			5385-101-007	
15	Conduit Box	5200-101-011	1	5200-101-011	1
16	Torque Arm	5384-101-013		5385-101-011	
	16a Capscrew	797-0418		797-0418	
	16b Lockwasher	950-0355		950-0355	
	16c Torque Arm	112-2006		112-2007	

*See page 20 for specific part numbers.

These units when used with the correct Warner Electric conduit box, meets the standards of UL508 and are listed under guide care #NMTR, file #59164. These units are CSA Certified under file #LR11543.

Bushing Part Numbers Browning Bushing

Shaft Size	Keyway Size	Bushing Number	
		Warner Electric	Browning
1/2	1/8 x 1/16	180-0002	H-1
9/16	1/8 x 1/6	180-0003	
5/8	3/16 x 3/32	180-0004	
11/16	3/16 x 3/32	180-0005	
3/4	3/16 x 3/32	180-0006	
13/16	3/16 x 3/32	180-0007	
7/8	3/16 x 3/32	180-0008	
15/16	1/4 x 1/8	180-0009	
1	1/4 x 1/8	180-0010	
1-1/6	1/4 x 1/8	180-0011	
1-1/8	1/4 x 1/8	180-0012	
1-3/16	1/4 x 1/8	180-0013	
1-1/4	1/4 x 3/16	180-0014	
1-5/16	5/16 x 7/32	180-0015	
1-3/8	5/16 x 7/32	180-0016	
1-7/16	3/8 x 1/4	180-0017	
1-1/2	3/8 x 7/32	180-0018	
3/4	1/2 x 3/8	180-0026	
13/16	1/2 x 3/8	180-0027	QI-1
7/8	1/2 x 3/8	180-0028	
15/16	1/2 x 3/8	180-0029	
1	1/2 x 3/8	180-0030	
1-1/16	1/2 x 3/8	180-0031	
1-1/8	1/2 x 3/8	180-0032	
1-3/16	1/2 x 3/8	180-0033	
1-1/4	1/2 x 3/8	180-0034	
1-5/16	1/2 x 3/8	180-0035	
1-3/8	1/2 x 3/8	180-0036	
1-7/16	1/2 x 3/8	180-0037	
1-1/2	1/2 x 3/8	180-0038	
1-9/16	1/2 x 3/8	180-0039	
1-5/8	1/2 x 3/8	180-0040	
1-11/16	1/2 x 3/8	180-0041	
1-3/4	1/2 x 3/8	180-0042	
1-13/16	1/2 x 3/8	180-0043	
1-7/8	1/2 x 3/8	180-0044	
1-15/16	1/2 x 3/8	180-0045	
2	1/2 x 3/8	180-0046	QI-2
2-1/16	1/2 x 3/8	180-0047	
2-1/8	1/2 x 3/4	180-0048	
2-3/16	1/2 x 23/32	180-0049	
2-1/4	1/2 x 11/16	180-0050	
2-5/16	5/8 x 5/16	180-0051	
2-3/8	5/8 x 5/16	180-0052	
2-7/16	5/8 x 5/16	180-0053	
2-1/2	5/8 x 5/16	180-0054	
2-9/16	5/8 x 5/16	180-0055	
2-5/8	5/8 x 5/16	180-0056	
2-11/16	5/8 x 5/16	180-0057	

Dodge Bushing

Shaft Size	Keyway Size	Bushing Number		
		Warner Electric	Dodge	
1/2	1/8 x 1/16	180-0101	1210	
9/16	1/8 x 1/16	180-0102		
5/8	3/16 x 3/32	180-0103		
11/16	3/16 x 3/32	180-0104		
3/4	3/16 x 3/32	180-0105		
13/16	3/16 x 3/32	180-0106		
7/8	3/16 x 3/32	180-0107		
5/16	1/4 x 1/8	180-0108		
1	1/4 x 1/8	180-0109		
1-1/16	1/4 x 1/8	180-0110		
1-1/8	1/4 x 1/8	180-0111		
1-3/16	1/4 x 1/8	180-0112		
1-1/4	1/4 x 1/8	180-0113		
1/2	1/8 x 1/16	180-0116		1215
9/16	1/8 x 1/16	180-0117		
5/8	3/16 x 3/32	180-0118		
11/16	3/16 x 3/32	180-0119		
3/4	3/16 x 3/32	180-0120		
13/16	3/16 x 3/32	180-0121		
7/8	3/16 x 3/32	180-0122		
15/16	1/4 x 1/8	180-0123		
1	1/4 x 1/8	180-0124		
1-1/16	1/4 x 1/8	180-0125		
1-1/8	1/4 x 1/8	180-0126		
1-3/16	1/4 x 1/8	180-0127		
1-1/4	1/4 x 1/8	180-0128	1615	
1/2	1/8 x 1/16	180-0131		
9/16	1/8 x 1/16	180-0132		
5/8	3/16 x 3/32	180-0133		
11/16	3/16 x 3/32	180-0134		
3/4	3/16 x 3/32	180-0135		
13/16	3/16 x 3/32	180-0136		
7/8	3/16 x 3/32	180-0137		
15/16	1/4 x 1/8	180-0138		
1	1/4 x 1/8	180-0139		
1-1/16	1/4 x 1/8	180-0140		
1-1/8	1/4 x 1/8	180-0141		
1-3/16	1/4 x 1/8	180-0142		
1-1/4	1/4 x 1/8	180-0143		
1-5/16	5/16 x 5/32	180-0144		
1-3/8	5/16 x 5/32	180-0145		
1-7/16	3/8 x 3/16	180-0146		
1-1/2	3/8 x 3/16	180-0147		
1-9/16	3/8 x 3/16	180-0148		
1-5/8	3/8 x 3/16	180-0149		
1/2	1/8 x 1/16	180-0155	2012	
9/16	1/8 x 1/16	180-0156		
5/8	3/16 x 3/32	180-0157		
11/16	3/16 x 3/32	180-0158		
3/4	3/16 x 3/32	180-0159		
13/16	3/16 x 3/32	180-0160		
7/8	3/16 x 3/32	180-0161		
15/16	1/4 x 1/8	180-0162		
1	1/4 x 1/8	180-0163		
1-1/16	1/4 x 1/8	180-0164		
1-1/8	1/4 x 1/8	180-0165		
1-3/16	1/4 x 1/8	180-0166		
1-1/4	1/4 x 1/8	180-0167		

Bushing Part Numbers

Dodge Bushing

Shaft Size	Keyway Size	Bushing Number		
		Warner Electric	Dodge	
1-5/16	5/16 x 5/32	180-0168	2012	
1-3/8	5/16 x 5/32	180-0169		
1-7/16	3/8 x 3/16	180-0170		
1-1/12	3/8 x 3/16	180-0171		
1-9/16	3/8 x 3/16	180-0172		
1-5/8	3/8 x 3/16	180-0173		
1-11/16	3/8 x 3/16	180-0174		
1-3/4	3/8 x 3/16	180-0175		
1-13/16	1/2 x 1/4	180-0176		
1-7/8	1/2 x 1/4	180-0177		
1-15/16	1/2 x 1/4	180-0178		
2	1/2 x 1/4	180-0179		
1/2	1/8 x 1/16	180-0185		2517
9/16	1/8 x 1/16	180-0186		
5/8	3/16 x 3/32	180-0187		
11/16	3/16 x 3/32	180-0188		
3/4	3/16 x 3/32	180-0189		
13/16	3/16 x 3/32	180-0190		
7/8	3/16 x 3/32	180-0191		
15/16	1/4 x 1/8	180-0192		
1	1/4 x 1/8	180-0193		
1-1/16	1/4 x 1/8	180-0194		
1-1/8	1/4 x 1/8	180-0195		
1-3/16	1/4 x 1/8	180-0196		
1-1/4	1/4 x 1/8	180-0197		
1-5/16	5/16 x 5/32	180-0198		
1-3/8	5/16 x 5/32	180-0199		
1-7/16	3/8 x 3/16	180-0200		
1-1/2	3/8 x 3/16	180-0201		
1-9/16	3/8 x 3/16	180-0202		
1-5/8	3/8 x 3/16	180-0203		
1-11/16	3/8 x 3/16	180-0204		
1-3/4	3/8 x 3/16	180-0205		
1-13/16	1/2 x 1/4	180-0206		
1-7/8	1/2 x 1/4	180-0207		
1-15/16	1/2 x 1/4	180-0208		
2	1/2 x 1/4	180-0209		
2-1/16	1/2 x 1/4	180-0210		
2-1/8	1/2 x 1/4	180-0211		
2-3/16	1/2 x 1/4	180-0212		
2-1/4	1/2 x 1/4	180-0213		
2-5/16	5/8 x 5/16	180-0214		
2-3/8	5/8 x 5/16	180-0215		
2-7/16	5/8 x 5/16	180-0216		
2-1/2	5/8 x 5/16	180-0217		
15/16	1/4 x 1/8	180-0223	3020	
1	1/4 x 1/8	180-0224		
1-1/16	1/4 x 1/8	180-0225		
1-1/8	1/4 x 1/8	180-0226		
1-3/16	1/4 x 1/8	180-0227		
1-1/4	1/4 x 1/8	180-0228		
1-5/16	5/16 x 5/32	180-0229		
1-3/8	5/16 x 5/32	180-0230		
1-7/16	3/8 x 3/16	180-0231		
1-1/2	3/8 x 3/16	180-0232		
1-9/16	3/8 x 3/16	180-0233		
1-5/8	3/8 x 3/16	180-0234		

Shaft Size	Keyway Size	Bushing Number	
		Warner Electric	Dodge
1-11/16	3/8 x 3/16	180-0235	3020
1-3/4	3/8 x 3/16	180-0236	
1-13/16	1/2 x 1/4	180-0237	
1-7/8	1/2 x 1/4	180-0238	
1-15/16	1/2 x 1/4	180-0239	
2	1/2 x 1/4	180-0240	
2-1/16	1/2 x 1/4	180-0241	
2-1/8	1/2 x 1/4	180-0242	
2-3/16	1/2 x 1/4	180-0243	
2-1/4	1/2 x 1/4	180-0244	
2-5/16	5/8 x 5/16	180-0245	
2-3/8	5/8 x 5/16	180-0246	
2-7/16	5/8 x 5/16	180-0247	
2-1/2	5/8 x 5/16	180-0248	
2-9/16	5/8 x 5/16	180-0249	
2-5/8	5/8 x 5/16	180-0250	
2-11/16	5/8 x 5/16	180-0251	
2-3/4	5/8 x 5/16	180-0252	
2-13/16	3/4 x 3/8	180-0253	
2-7/8	3/4 x 3/8	180-0254	
2-15/16	3/4 x 3/8	180-0255	
3	3/4 x 3/8	180-0256	
15/16	1/4 x 1/8	180-0262	3030
1	1/4 x 1/8	180-0263	
1-1/16	1/4 x 1/8	180-0264	
1-1/8	1/4 x 1/8	180-0265	
1-3/16	1/4 x 1/8	180-0266	
1-1/4	1/4 x 1/8	180-0267	
1-5/16	5/16 x 5/32	180-0268	
1-3/8	5/16 x 5/32	180-0269	
1-7/16	3/8 x 3/16	180-0270	
1-1/2	3/8 x 3/16	180-0271	
1-9/16	3/8 x 3/16	180-0272	
1-5/8	3/8 x 3/16	180-0273	
1-11/16	3/8 x 3/16	180-0274	
1-3/4	3/8 x 3/16	180-0275	
1-13/16	1/2 x 1/4	180-0276	
1-7/8	1/2 x 1/4	180-0277	
1-15/16	1/2 x 1/4	180-0278	
2	1/2 x 1/4	180-0279	
2-1/16	1/2 x 1/4	180-0280	
2-1/8	1/2 x 1/4	180-0281	
2-3/16	1/2 x 1/4	180-0282	
2-1/4	1/2 x 1/4	180-0283	
2-15/16	5/8 x 5/16	180-0284	
2-3/8	5/8 x 5/16	180-0285	
2-7/16	5/8 x 5/16	180-0286	
2-1/2	5/8 x 5/16	180-0287	
2-9/16	5/8 x 5/16	180-0288	
2-5/8	5/8 x 5/16	180-0289	
2-11/16	5/8 x 5/16	180-0290	
2-3/4	5/8 x 5/16	180-0291	
2-13/16	3/4 x 3/8	180-0292	
2-7/8	3/4 x 3/8	180-0293	
2-15/16	3/4 x 3/8	180-0294	
3	3/4 x 3/8	180-0295	

Bushing Part Numbers

Dodge Bushing

Shaft Size	Keyway Size	Bushing Number	
		Warner Electric	Dodge
1/2	1/8 x 1/16	180-0326	1610
9/16	1/8 x 1/16	180-0327	
5/8	3/16 x 3/32	180-0328	
11/16	3/16 x 3/32	180-0329	
3/4	3/16 x 3/32	180-0330	
13/16	3/16 x 3/32	180-0331	
7/8	3/16 x 3/32	180-0332	
15/16	1/4 x 1/8	180-0333	
1	1/4 x 1/8	180-0334	
1-1/16	1/4 x 1/8	180-0335	
1-1/8	1/4 x 1/8	180-0336	
1-3/16	1/4 x 1/8	180-0337	
1-1/4	1/4 x 1/8	180-0338	
1-5/16	5/16 x 5/32	180-0339	
1-3/8	5/16 x 5/32	180-0340	
1-7/16	3/8 x 3/16	180-0341	
1-1/2	3/8 x 3/16	180-0342	
1-9/16	3/8 x 3/16	180-0343	
1-5/8	3/8 x 3/16	180-0344	
1/2	1/8 x 1/16	180-0410	
9/16	1/18 x 1/16	180-0411	
5/8	3/16 x 3/32	180-0412	
11/16	3/16 x 3/32	180-0413	
3/4	3/16 x 3/32	180-0414	
13/16	3/16 x 3/32	180-0415	
7/8	3/16 x 3/32	180-0416	
15/16	1/4 x 1/16	180-0417	
1	1/4 x 1/16	180-0418	
1/2	1/8 x 1/16	180-0421	1310
9/16	1/8 x 1/16	180-0422	
5/8	3/16 x 3/32	180-0423	
11/16	3/16 x 3/32	180-0424	
3/4	3/16 x 3/32	180-0425	
13/16	3/16 x 3/32	180-0426	
7/8	3/16 x 3/32	180-0427	
15/16	1/4 x 1/16	180-0428	
1	1/4 x 1/16	180-0429	
1-1/16	1/4 x 1/8	180-0430	
1-1/8	1/4 x 1/8	180-0431	
1-3/16	1/4 x 1/8	180-0432	
1-1/4	1/4 x 1/8	180-0433	
1-5/16	15/16 x 5/32	180-0434	
1-3/8	15/16 x 5/32	180-0435	

Warranty

Warner Electric LLC warrants that it will repair or replace (whichever it deems advisable) any product manufactured and sold by it which proves to be defective in material or workmanship within a period of one (1) year from the date of original purchase for consumer, commercial or industrial use.

This warranty extends only to the original purchaser and is not transferable or assignable without Warner Electric LLC's prior consent.

Warranty service can be obtained in the U.S.A. by returning any defective product, transportation charges prepaid, to the appropriate Warner Electric LLC factory. Additional warranty information may be obtained by writing the Customer Satisfaction Department, Warner Electric LLC, 449 Gardner Street, South Beloit, Illinois 61080, or by calling 815-389-3771.

A purchase receipt or other proof of original purchase will be required before warranty service is rendered. If found defective under the terms of this warranty, repair or replacement will be made, without charge, together with a refund for transportation costs. If found not to be defective, you will be notified and, with your consent, the item will be repaired or replaced and returned to you at your expense.

This warranty covers normal use and does not cover damage or defect which results from alteration, accident, neglect, or improper installation, operation, or maintenance.

Some states do not allow limitation on how long an implied warranty lasts, so the above limitation may not apply to you.

Warner Electric LLC's obligation under this warranty is limited to the repair or replacement of the defective product and in no event shall Warner Electric LLC be liable for consequential, indirect, or incidental damages of any kind incurred by reason of the manufacture, sale or use of any defective product. Warner Electric LLC neither assumes nor authorizes any other person to give any other warranty or to assume any other obligation or liability on its behalf.

WITH RESPECT TO CONSUMER USE OF THE PRODUCT, ANY IMPLIED WARRANTIES WHICH THE CONSUMER MAY HAVE ARE LIMITED IN DURATION TO ONE YEAR FROM THE DATE OF ORIGINAL CONSUMER PURCHASE. WITH RESPECT TO COMMERCIAL AND INDUSTRIAL USES OF THE PRODUCT, THE FOREGOING WARRANTY IS IN LIEU OF AND EXCLUDES ALL OTHER WARRANTIES, WHETHER EXPRESSED OR IMPLIED BY OPERATION OF LAW OR OTHERWISE, INCLUDING, BUT NOT LIMITED TO, ANY IMPLIED WARRANTIES OF MERCHANTABILITY OR FITNESS.

Some states do not allow the exclusion or limitation of incidental or consequential damages, so the above limitation or exclusion may not apply to you. This warranty gives you specific legal rights and you may also have other rights which vary from state to state.

Changes in Dimensions and Specifications

All dimensions and specifications shown in Warner Electric catalogs are subject to change without notice. Weights do not include weight of boxing for shipment. Certified prints will be furnished without charge on request to Warner Electric.



Warner Electric LLC
449 Gardner Street • South Beloit, IL 61080
815-389-3771 • Fax: 815-389-2582
www.warnerelectric.com