

# novopress

## Mastering Innovations

Creating competitive advantages through innovation. That's the key driver for our unique solutions in the electrical industry.

Efficient busbar manufacturing lines and innovative dieless crimping tools, provide the competitive edge for our global customers.

**novopress**

## HSBL-2 Cutting Tool 120

For stationary and portable cutting applications up to 120 x 13 mm (4" x 1/2"), the HSBL-2 Cutting Tool 120, is the right choice. State of the art operator safety, easy transport and precise cutting with highest quality, are making the HSBL-2 Cutting Tool 120 ideal for small work shops or on site maintenance.

Technical Data		Ref. 2350
Height	785 mm (incl. work-cylinder)	
Depth	200 mm	
Width	210 mm	
Weight	12 kg	
Operating pressure	150 bar	
Force	150 KN	
Cutting perf. max.	120 x 13 mm 250 N/mm <sup>2</sup>	
Cycle time	12 sec.	

Recommended power packs: HA 1 - ES, HA 3, HA 4.

### Order Numbers

O/N 2350	Cutting tool 120 x 13 mm
O/N 6950	Centering vice for O/N 2350
O/N 6990	Length stop for O/N 2350



HSBL-2 Cutting Tool 120 -  
Precise cutting with highest quality.

## HSBL-2 Punching Tool 120

For stationary and portable punching applications up to 120 x 13 mm (4" x 1/2"), the HSBL-2 Punching Tool 120, is the right choice. State of the art operator safety, easy transport and excellent punching quality with round, elongated and square dies, are making the HSBL-2 Punching Tool 120 the ideal option for small work shops and on site maintenance.

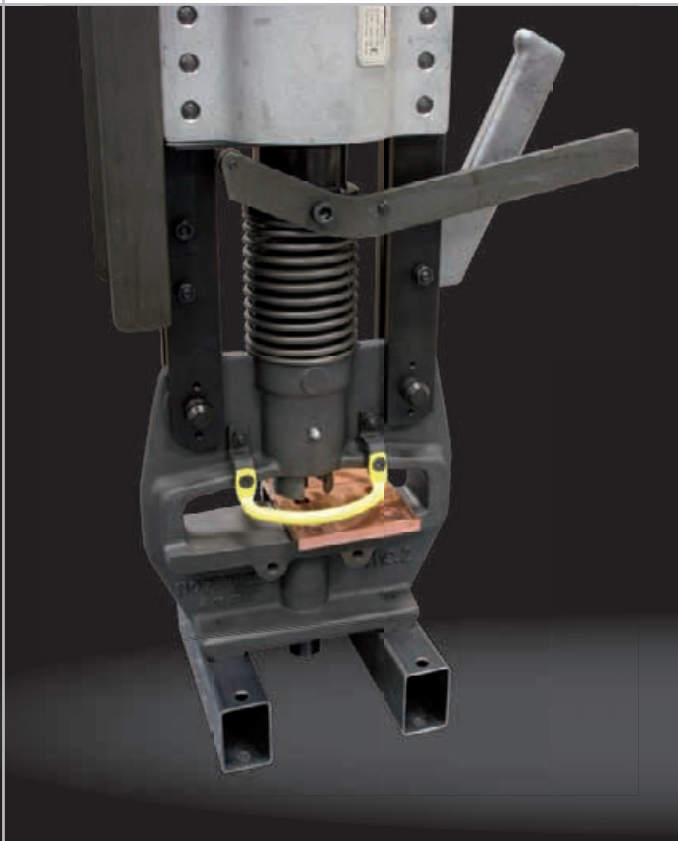

Technical Data		Ref. 1118
Height	860 mm (incl. work-cylinder)	
Depth	200 mm	
Width	260 mm	
Weight	15 kg	
Operating pressure	150 bar	
Force	150 KN	
Cutting perf. max.	120 x 13 mm 250 N/mm <sup>2</sup>	
Cycle time	3 sec.*	

\* Busbar 120 x 10 mm  
Recommended power packs: HA 1 - ES, HA 3, HA 4.

### Order Numbers

O/N 1118	Punching tool 120 x 13 mm
O/N 1179	Bending Tool 120, portable
O/N 1627	Hydraulic stop valve for O/N 1179

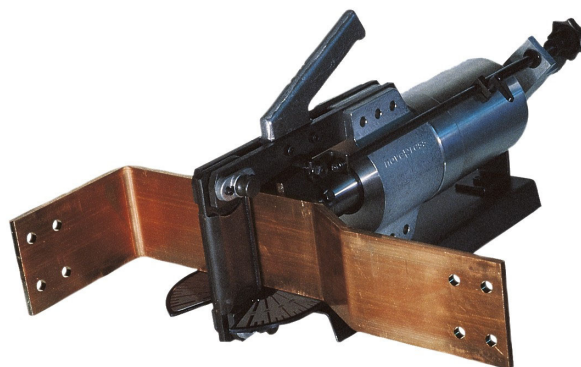

## Ref. 39661 HSBL-2 Starter System

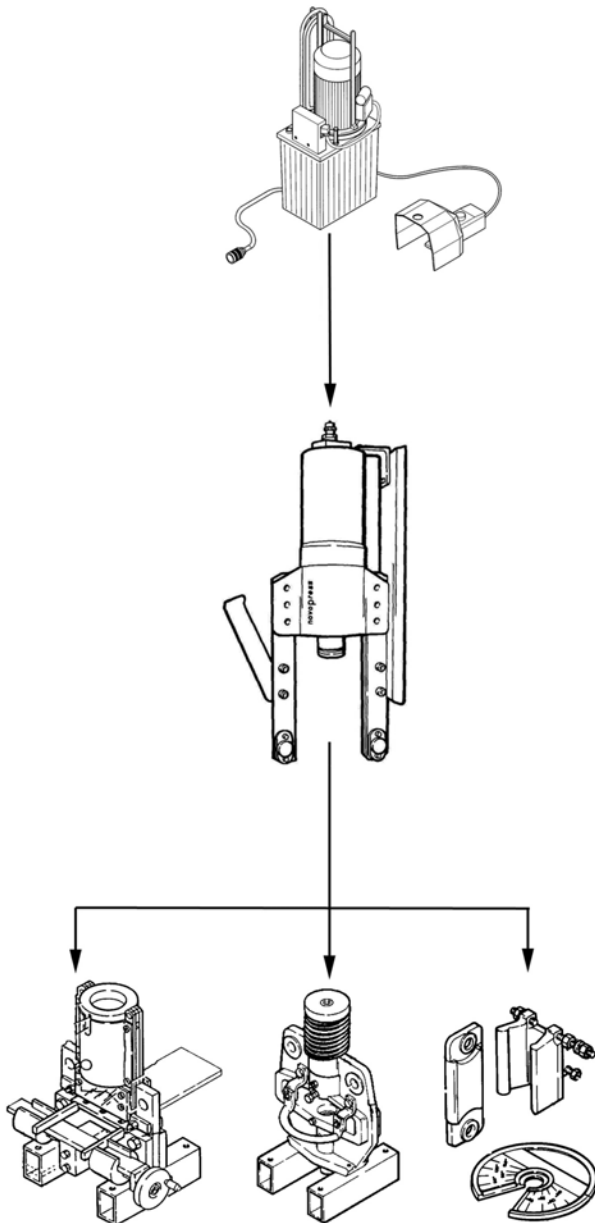

Ref. 32530 Power Pack HA3

Ref. 2420 HSBL-2 Work cylinder

Ref. 2350 Cutting Tool 120

Ref. 1118 Punching Tool 120

Ref. 200090 Die set 9.0mm

Ref. 200110 Die set 11.0mm

Ref. 200140 Die set 14.0mm

Ref. 1179 Bending Tool 120

Ref. 1627 Hydr. Stop for 1179