

Clutch Coupling

PCC-1525

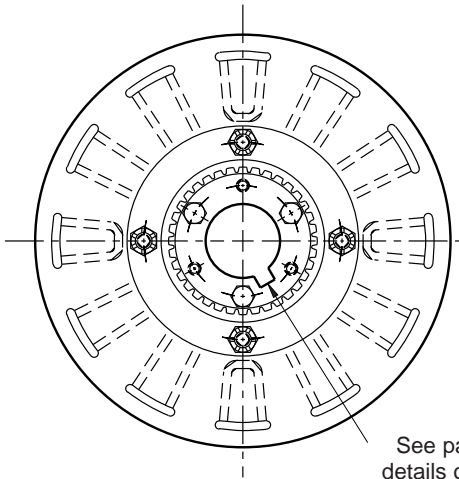

ARMATURE VIEW

See page 252 for details on Bushings.

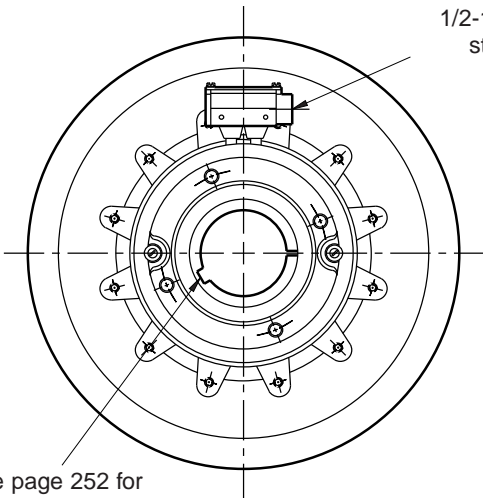

**PCC-1525
COLLECTOR RING VIEW**

1/2-14 NPSM Am. std. straight pipe tap.

See page 252 for details on Bushings.

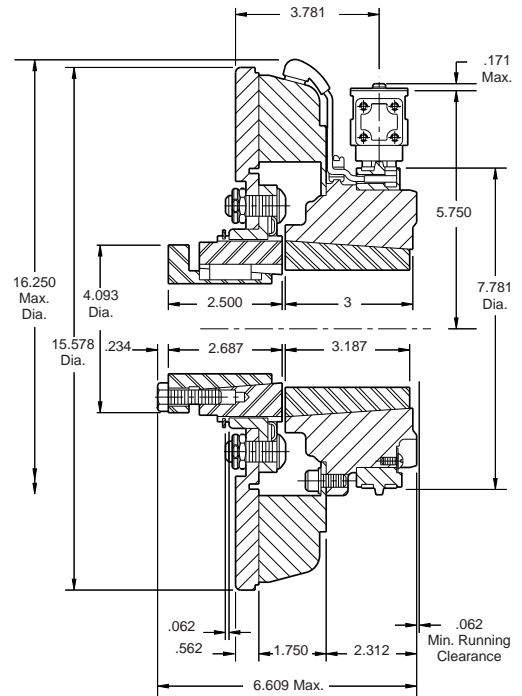

Armature Shaft	.750 – 2.687
Magnet Shaft	.937 – 3.00
Static Torque	700 lb.ft.
Maximum Speed	2,000 rpm
Standard Voltage	D.C. 6, 24, 90

Customer Shall Maintain:

1. Armature mounting shaft concentric with magnet mounting shaft within .006 T.I.R.
2. Angular alignment of shafts within 1/2 degree.

All dimensions are nominal unless otherwise noted.

Information on inertia and weights begins on page 239. Coil data is on pages 250 and 251.



Drawing I-25632

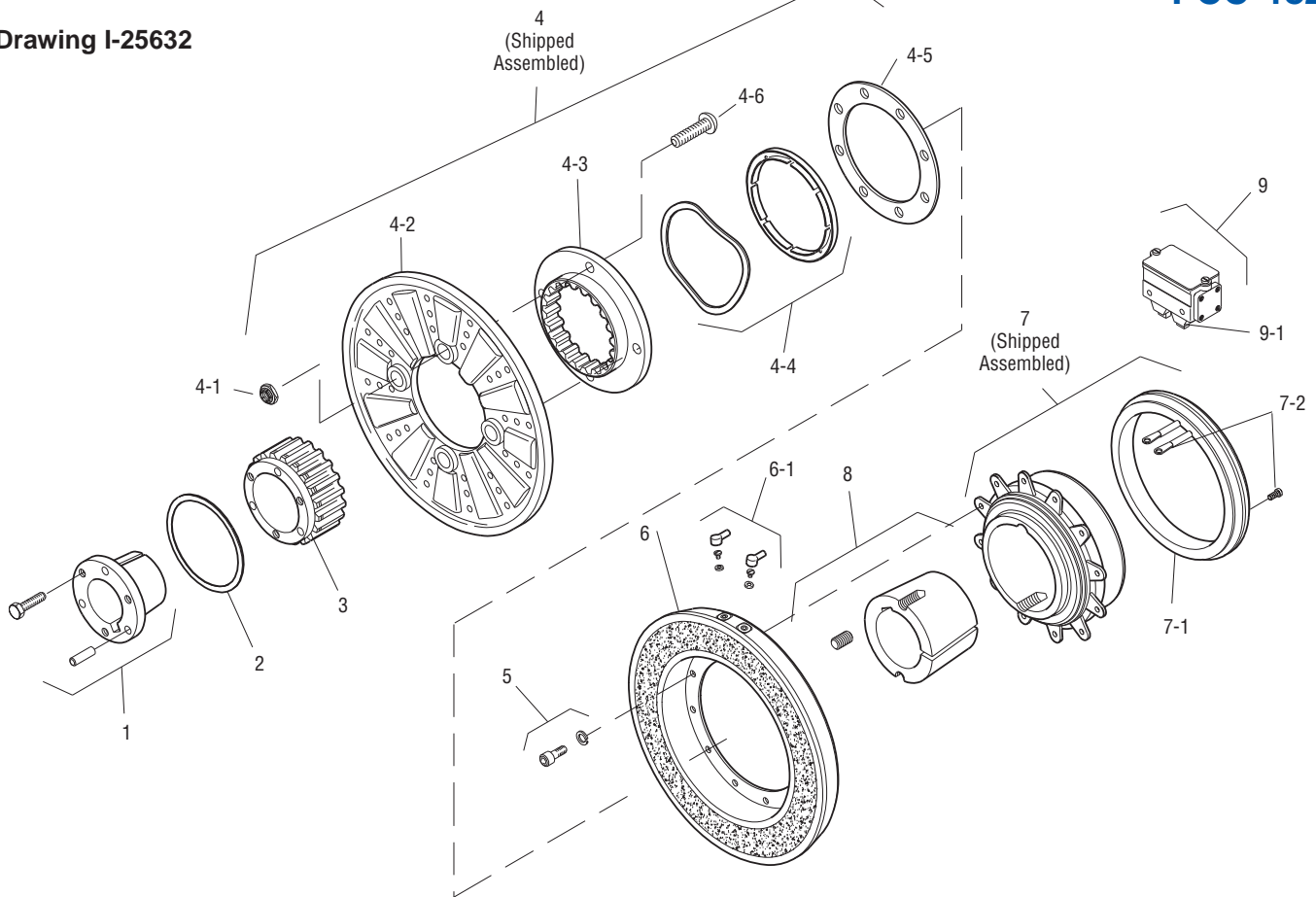

Item	Description	Part Number	Qty.
1	Bushing*		1
	3/4" to 2-11/16" Bore	180-0026 to 180-0057	
2	Retainer Ring	748-0005	1
3	Splined Hub	540-0064	1
4	Armature & Splined Adapter	5324-111-001	1
4-1	Locknut	661-0004	8
4-2	Armature	5324-111-034	1
4-3	Splined Adapter	104-0011	1
4-4	Autogap Accessory	5323-101-002	1
4-5	Retainer Plate	686-0003	1
4-6	Screw	797-0272	8
5	Mounting Accessory	5321-101-001	2
6	Magnet		1
	6 Volt	5304-631-009	
	24 Volt	5304-631-011	
	90 Volt	5304-631-010	
6-1	Terminal Accessory	5311-101-001	1
7	Magnet Hub		1
	Left Hand (shown)	5304-541-001	
	Right Hand	5304-541-002	
7-1	Collector Ring	5301-749-001	1
7-2	Collector Ring Accessory	5304-101-004	1

Item	Description	Part Number	Qty.
8	Bushing*		1
	15/16" to 3" Bore	180-0262 to 180-0295	
9	Brushholder	5300-178-001	1
9-1	Brush	176-0001	4

How to Order:

1. Specify Bore Size for Item 1.
2. Specify Voltage for Item 6.
3. Specify left hand or right hand hub for Item 7. (Bushing enters from magnet side for L.H. hub and from hub side for R.H.)
4. Specify Bore Size for Item 8.
5. See Controls Section.

Example:

PCC-1525 Clutch Coupling per I-25632 - 90 Volt, L.H. hub, 1-1/2" Bore (Item 1), 2" Bore (Item 8)

These units meet the standards of UL508 and are listed under guide card #NMTR2, file #59164.

These units are CSA certified under file #LR11543.

*See page 252 for specific part numbers.

Refer to Service Manual P-206.