

Clutch

SF-400 Flange Mounted

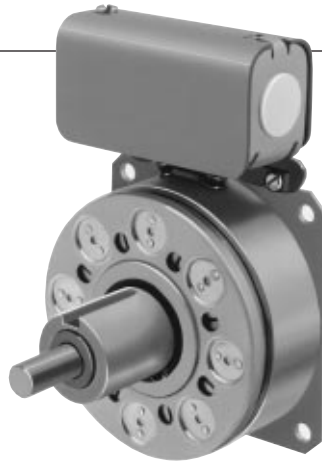

For Bore & Keyway sizes see chart below.

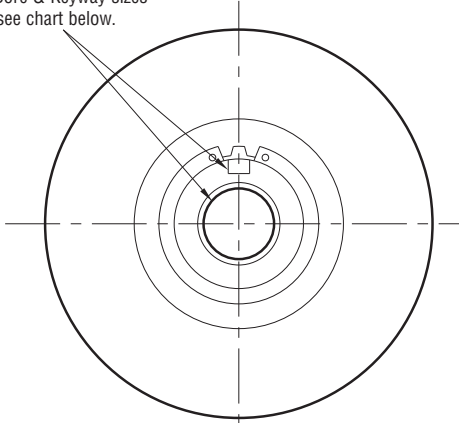

ARMATURE VIEW

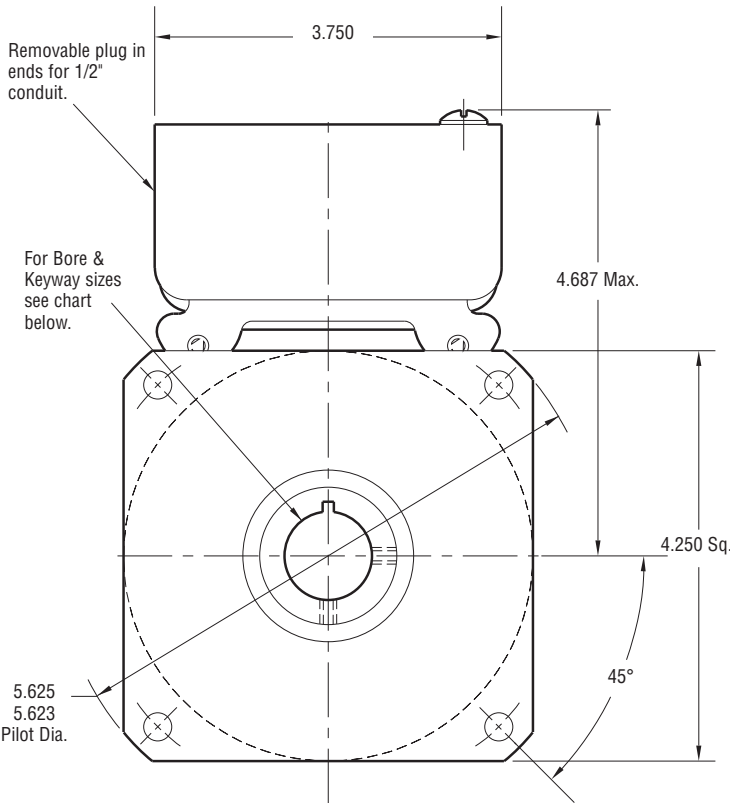

FIELD VIEW

Customer Shall Maintain:

1. Squareness of field mounting face with shaft within .003 T.I.R. measured at pilot diameter.
2. Concentricity of field mounting pilot diameter with rotor mounting shaft within .003 T.I.R.
- *3. Customer shall maintain dimension as noted.

.296/.280 dia. (4) holes equally spaced on 5.000 dia. Mounting holes are within .010 of true position relative to pilot diameter.

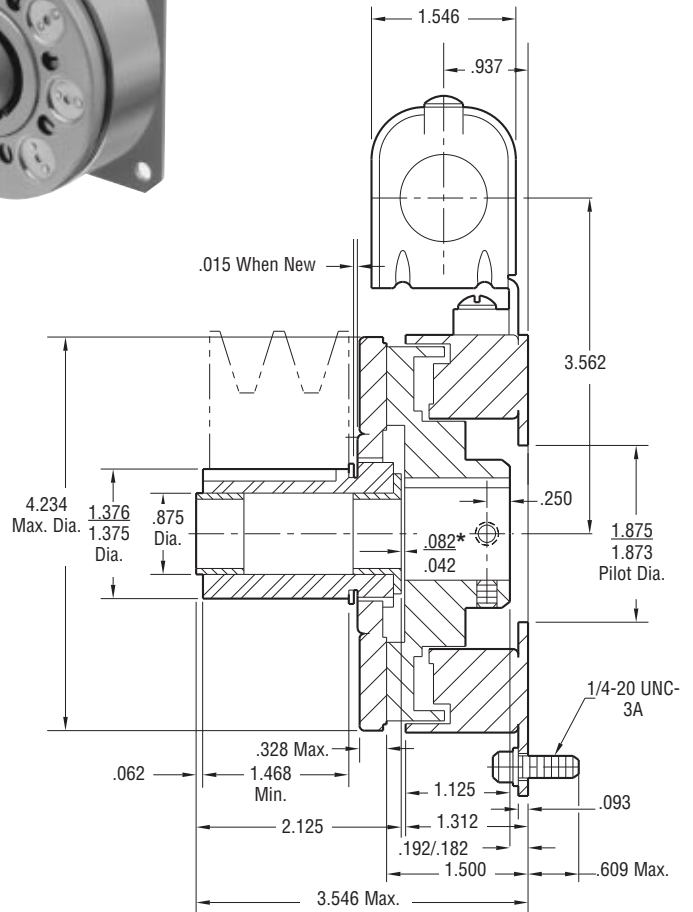

Bore and Keyway Dimensions

Armature Bore Dia.	Keyway	Rotor Bore Dia.	Keyway
.5000/.4995	.312 x .156	.501/.500	.125 x .062
.6250/.6245	x 1.25	.626/.625	
.7500/.7495		.751/.750	.187 x .093

Static Torque	270 lb.in.
Maximum Speed	4,500 rpm
Standard Voltage	D.C. 6, 24, 90

All dimensions are nominal unless otherwise noted.

Information on inertia and weights begins on page 239. Coil data is on pages 250 and 251.



Drawing I-25695

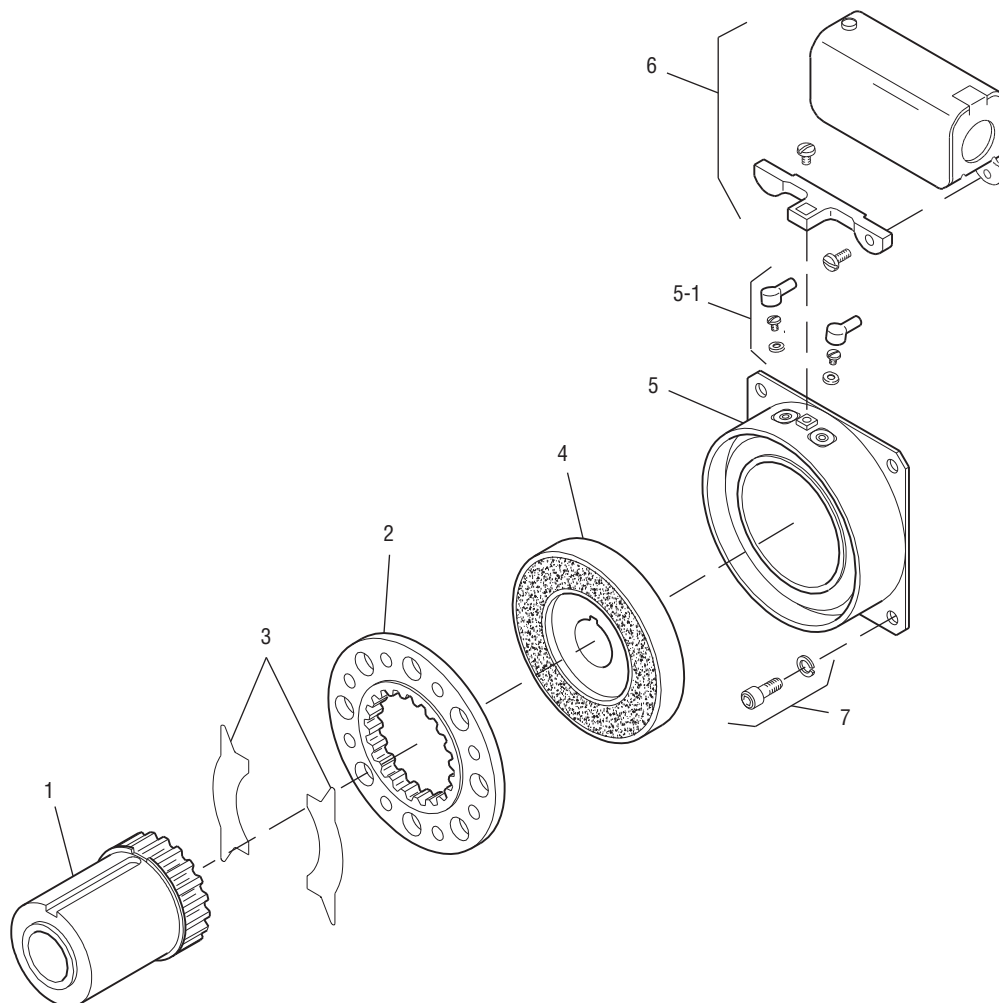

Item	Description	Part Number	Qty.
1	Armature Hub		1
	1/2" Bore	5125-541-002	
	5/8" Bore	5125-541-003	
	3/4" Bore	5125-541-004	
2	Armature	5125-111-001	1
3	Release Spring	5104-101-003	1
4	Rotor		1
	1/2" Bore	5104-751-033	
	5/8" Bore	5104-751-034	
	3/4" Bore	5104-751-035	
5	Field		1
	6 Volt	5104-451-032	
	24 Volt	5104-451-033	
	90 Volt	5104-451-034	
5-1	Terminal Accessory	5103-101-002	1
6	Conduit Box	5200-101-010	1
7	Mounting Accessory	5104-101-002	1

How to Order:

1. Specify Bore Size for Items 1 and 4.
2. Specify Voltage for Item 5.
3. See Controls Section.

Example:

SF-400 Clutch per I-25695 - 90 Volt
 3/4" Armature Hub Bore
 3/4" Rotor Bore

These units, when used in conjunction with the correct Warner Electric conduit box, meet the standards set of UL508 and are listed under guide card #NMTR2, file #59164.

These units are CSA certified under file #LR11543

Refer to Service Manual P-200.