

**SF-825 Bearing Mounted**

See page 230 for details on Drive Pin Mountings.

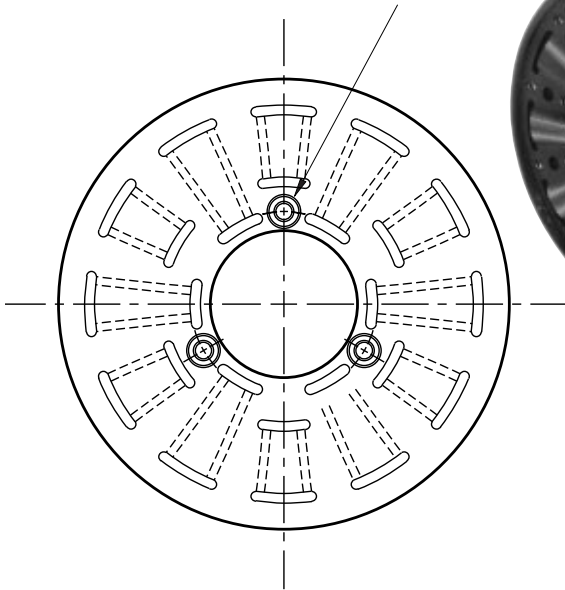

**ARMATURE VIEW**

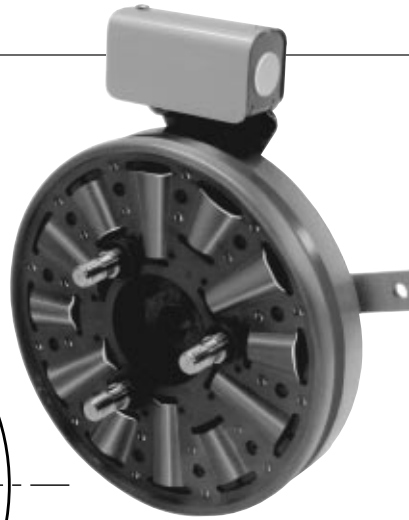
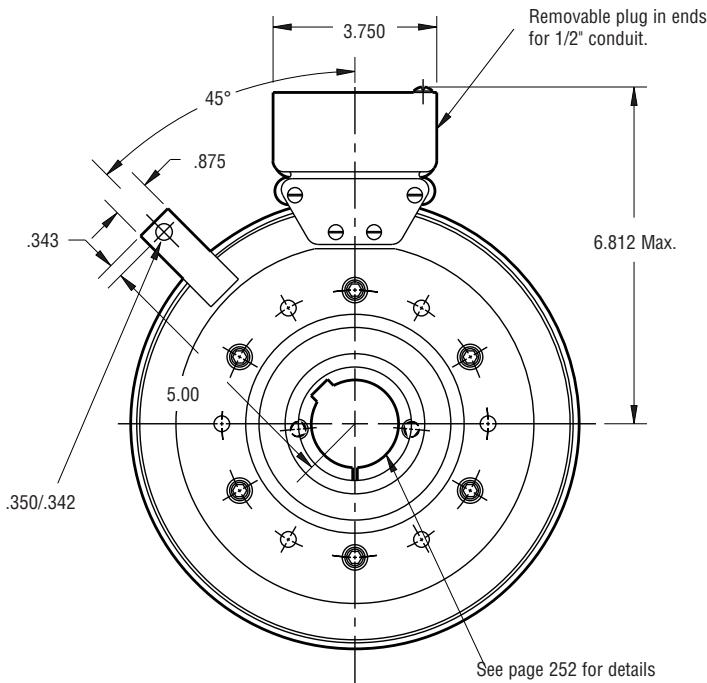
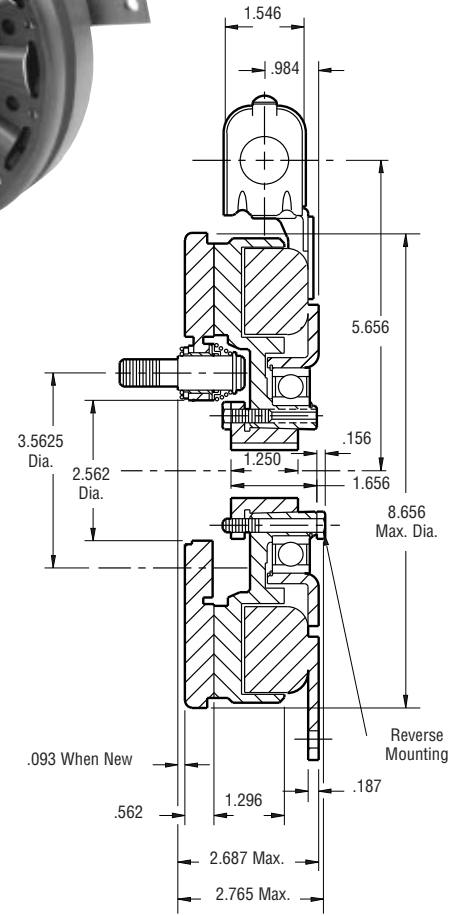

**FIELD VIEW**

See page 252 for details on Bushings.

Shaft Size	.500 – 1.500
Static Torque	150 lb.ft.
Maximum Speed	3,600 rpm
Standard Voltage	D.C. 6, 24, 90

All dimensions are nominal unless otherwise noted.

Information on inertia and weights begins on page 239. Coil data is on pages 250 and 251.



Drawing I-25575

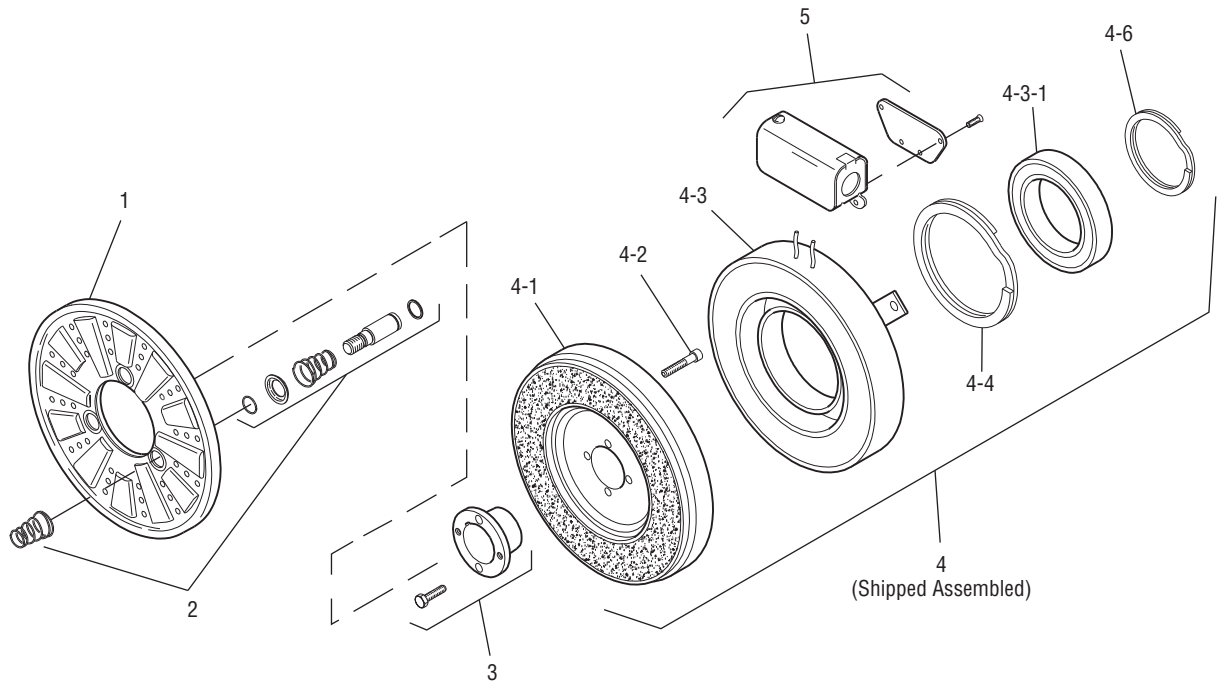

Item	Description	Part Number	Qty.
1	Armature	5301-111-018	1
2	Autogap Accessory	5201-101-008	3
3	Bushing*		1
	1/2" to 1-1/2" Bore	180-0002 to 180-0018	
4	Field & Rotor Assembly		1
	6 Volt	5201-452-002	
	24 Volt	5201-452-004	
	90 Volt	5201-452-006	
4-1	Rotor		1
	Standard Friction Material	5201-751-008	
4-2	Mounting Accessory	5201-101-005	1
4-3	Field & Bearing Assembly		1
	6 Volt	5201-451-054	
	24 Volt	5201-451-056	
	90 Volt	5201-451-057	
4-3-1	Ball Bearing	166-0142	1
4-4	Retainer Ring	748-0111	1
4-6	Retainer Ring	748-0016	1
5	Conduit Box	5200-101-012	1

**How to Order:**

1. Specify Bore Size for Item 3.
2. Specify Voltage for Item 4.
4. See Controls Section.

**Example:**

SF-825 Clutch per I-25575 - 90 Volt, 1" Bore

These units, when used in conjunction with the correct Warner Electric conduit box, meet the standards of UL508 and are listed under guide card #NMTR, file #59164. These units are CSA certified under file #LR11543.

\*See page 252 for specific part numbers.

Refer to Service Manual P-215.