

Clutch/Brake Coupling

SFPBC-500 Normal Duty

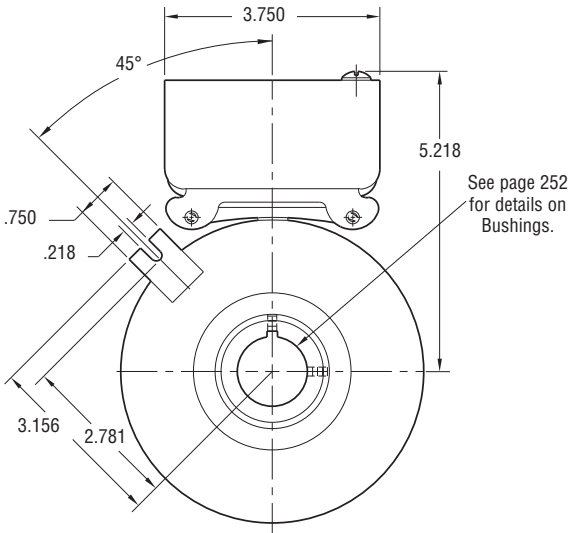

FIELD VIEW

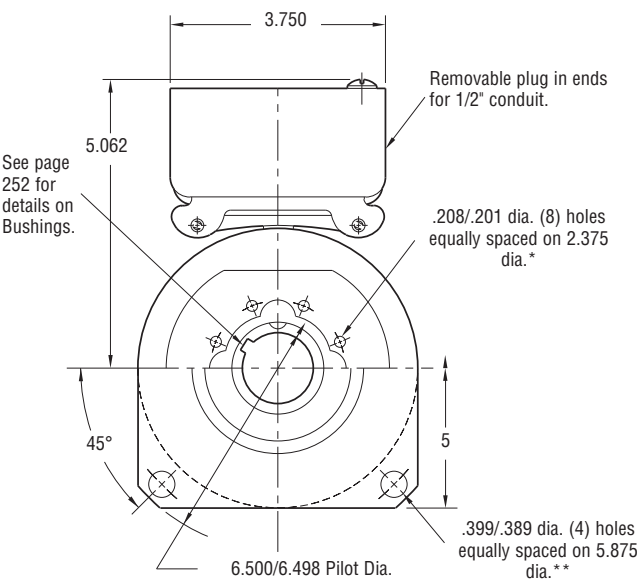

MAGNET VIEW

* Mounting holes are within .010 of true position relative to pilot diameter.

** Mounting holes are within .008 of true position relative to pilot diameter.

Customer Shall Maintain:

1. Squareness of brake mounting face with armature hub shaft within .006 T.I.R.
2. Concentricity of brake mounting pilot diameter with armature hub shaft within .010 T.I.R.
3. Concentricity of clutch magnet hub assembly shaft with armature hub shaft within .006 T.I.R.

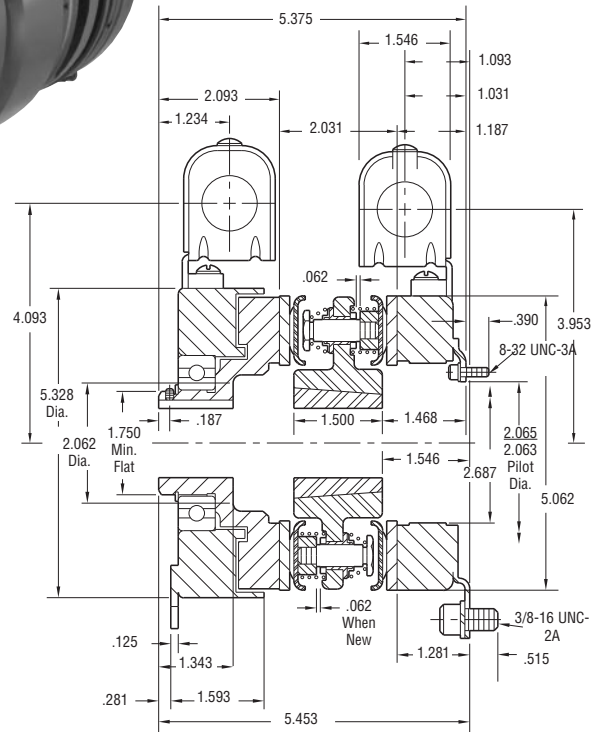

Outside Mounted Offset Backing Plate

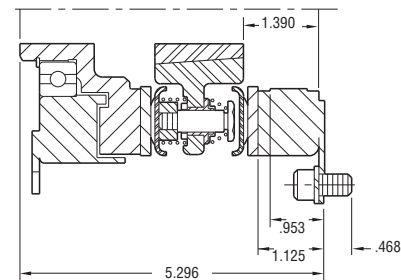

Outside Mounted Flush Backing Plate

Shaft Size	.750 – 1.250
Static Torque Clutch	50 lb. ft.
Static Torque Brake	40 lb. ft.
Maximum Speed	4,000 rpm
Standard Voltage	D.C. 6, 24, 90

All dimensions are nominal unless otherwise noted.

Information on inertia and weights begins on page 239. Coil data is on pages 250 and 251.

Clutch/Brake Coupling

SFPBC-500 Normal Duty

Drawing I-25546

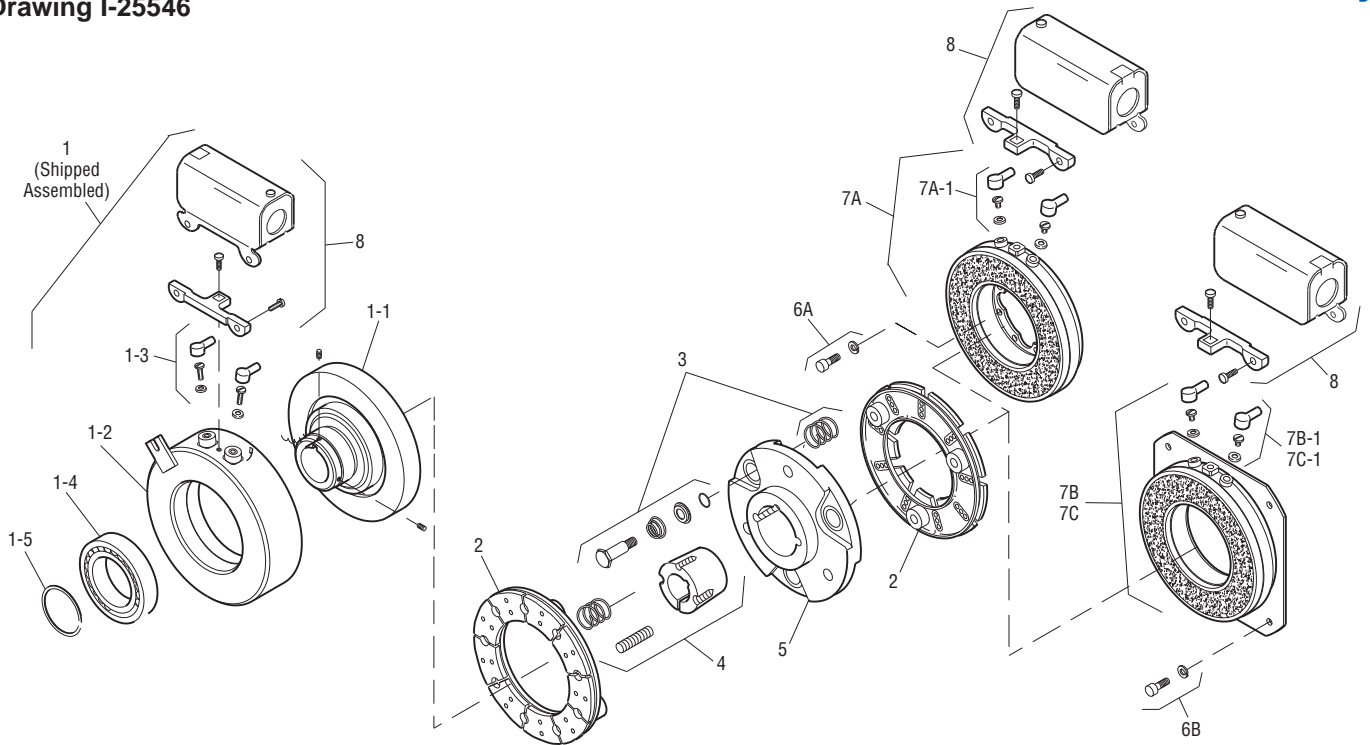

Item	Description	Part Number	Qty.
1	Field and Rotor Assembly		1
	6 Volt – 3/4" Bore	5200-452-002	
	24 Volt – 3/4" Bore	5200-452-004	
	90 Volt – 3/4" Bore	5200-452-005	
	6 Volt – 7/8" Bore	5200-452-008	
	24 Volt – 7/8" Bore	5200-452-010	
	90 Volt – 7/8" Bore	5200-452-011	
	90 Volt – 15/16" Bore	5200-452-017	
	6 Volt – 1" Bore	5200-452-020	
	24 Volt – 1" Bore	5200-452-022	
	90 Volt – 1" Bore	5200-452-023	
	6 Volt – 1-1/8" Bore	5200-452-026	
	24 Volt – 1-1/8" Bore	5200-452-028	
	90 Volt – 1-1/8" Bore	5200-452-029	
	6 Volt – 1-1/4" Bore	5200-452-032	
	90 Volt – 1-1/4" Bore	5200-452-035	
1-1	Rotor		1
	3/4" Bore	5200-751-002	
	7/8" Bore	5200-751-003	
	15/16" Bore	5200-751-004	
	1" Bore	5200-751-005	
	1-1/8" Bore	5200-751-006	
	1-1/4" Bore	5200-751-007	
1-2	Field		1
	6 Volt	5200-451-002	
	24 Volt	5200-451-004	
	90 Volt	5200-451-005	
1-3	Terminal Accessory	5311-101-001	1
1-4	Ball Bearing	166-0110	1
1-5	Retainer Ring	748-0002	1
2	Armature	5300-111-002	2
3	Autogap Accessory	5200-101-009	6
4	Bushing*- 1/2" to 1-1/4" Bore	180-0116 to 180-0128	1
5	Armature Hub	5300-541-004	1

Item	Description	Part Number	Qty.
6A	Mounting Accessory - I.M.	5102-101-001	2
6B	Mounting Accessory - O.M.	5300-101-008	1
7A	Magnet - I.M.		1
	6 Volt	5300-631-002	
	24 Volt	5300-631-003	
	90 Volt	5300-631-005	
7A-1	Terminal Accessory	5311-101-001	1
7B	Magnet - O.M. - Offset		1
	90 Volt	5300-631-014	
7B-1	Terminal Accessory	5311-101-001	1
7C	Magnet - O.M. - Flush		1
	6 Volt	5300-631-009	
	24 Volt	5300-631-010	
	90 Volt	5300-631-011	
7C-1	Terminal Accessory	5311-101-001	1
8	Conduit Box	5200-101-010	2

How to Order:

1. Specify Bore Size for Item 1 and Item 4.
2. Specify Voltage for Item 1 and Item 7A, 7B or 7C.
3. Specify Inside Mounted for Item 7A and Outside Mounted (Offset) for Item 7B or Outside Mounted (Flush) for Item 7C.
4. See Controls Section.

Example:

SFPBC-500 Clutch Brake Coupling per I-25546 - 90 Volt, Inside Mounted, 1" Bore

These units, when used in conjunction with the correct Warner Electric conduit box, meet the standards of UL508 and are listed under guide card #NMTR, file #59164.

These units are CSA certified under file #LR11543.

*See page 252 for specific part numbers.

Refer to Service Manual P-202.

Clutch/Brake Coupling

SFPBC-500 Heavy Duty

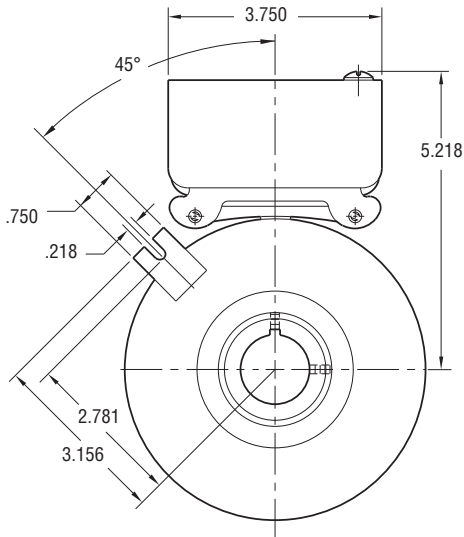

FIELD VIEW

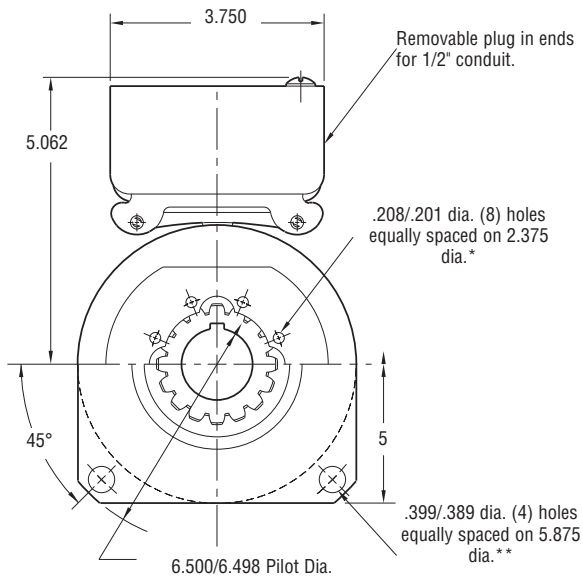

MAGNET VIEW

* Mounting holes are within .010 of true position relative to pilot diameter.

** Mounting holes are within .008 of true position relative to pilot diameter.

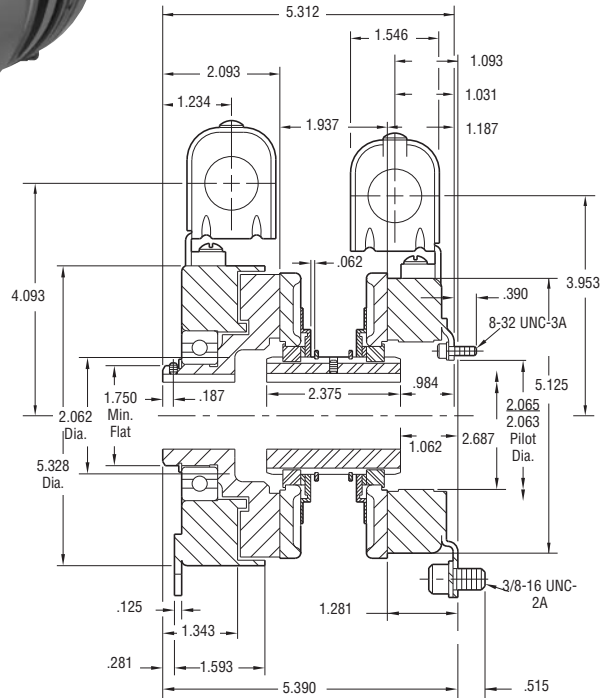

Outside Mounted Offset Backing Plate

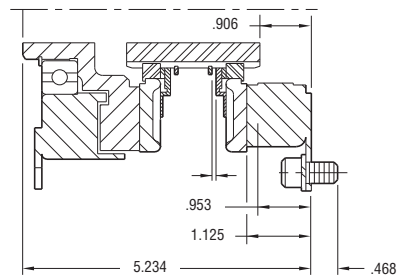

Outside Mounted Flush Backing Plate

Customer Shall Maintain:

1. Squareness of brake mounting face with armature hub shaft within .006 T.I.R.
2. Concentricity of brake mounting pilot diameter with armature hub shaft within .010 T.I.R.
2. Concentricity of clutch magnet hub assembly shaft with armature hub shaft within .006 T.I.R.



Shaft Size	.750 – 1.250
Static Torque Clutch	50 lb. ft.
Static Torque Brake	40 lb. ft.
Maximum Speed	4,000 rpm
Standard Voltage	D.C. 6, 24, 90

All dimensions are nominal unless otherwise noted.

Information on inertia and weights begins on page 239. Coil data is on pages 250 and 251.

Clutch/Brake Coupling

SFPBC-500 Heavy Duty

Drawing I-25554

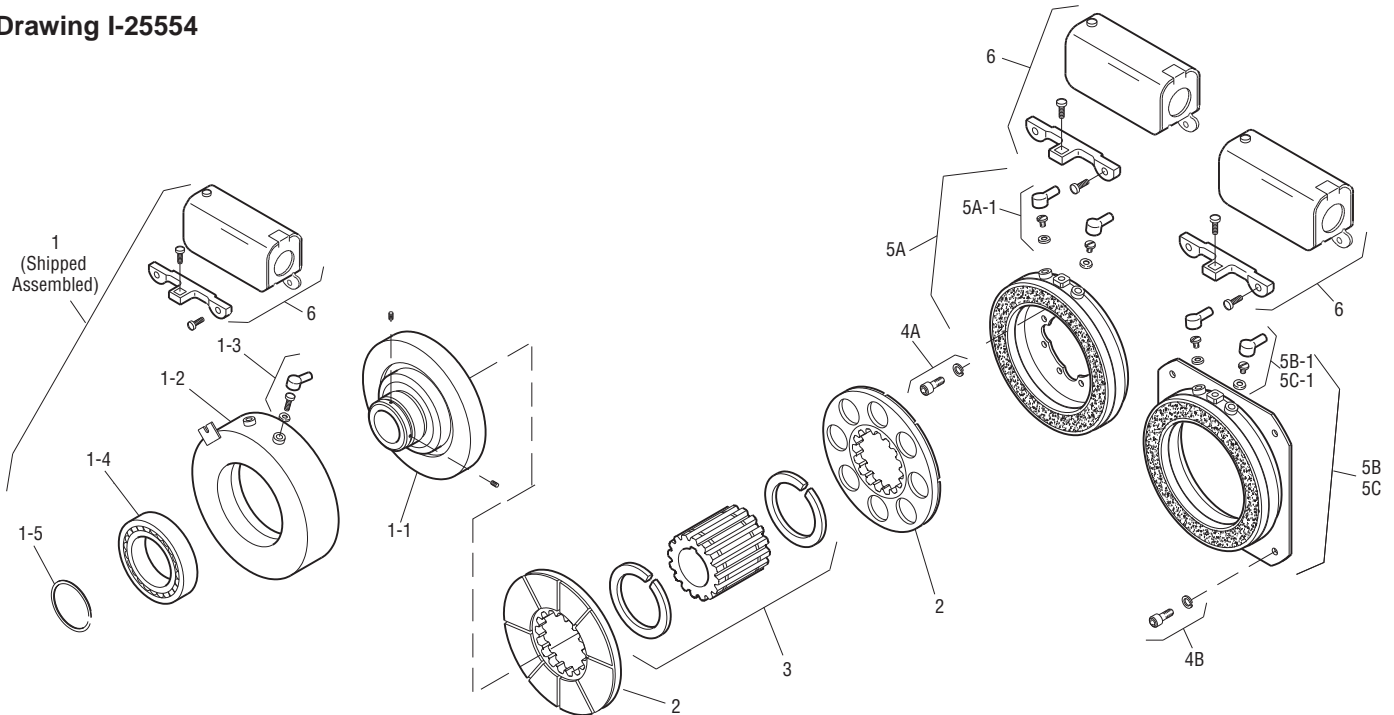

Item	Description	Part Number	Qty.
1	Field and Rotor Assembly		1
	6 Volt – 3/4" Bore	5200-452-002	
	24 Volt – 3/4" Bore	5200-452-004	
	90 Volt – 3/4" Bore	5200-452-005	
	6 Volt – 7/8" Bore	5200-452-008	
	24 Volt – 7/8" Bore	5200-452-010	
	90 Volt – 7/8" Bore	5200-452-011	
	90 Volt – 15/16" Bore	5200-452-017	
	6 Volt – 1" Bore	5200-452-020	
	24 Volt – 1" Bore	5200-452-022	
	90 Volt – 1" Bore	5200-452-023	
	6 Volt – 1-1/8" Bore	5200-452-026	
	24 Volt – 1-1/8" Bore	5200-452-028	
	90 Volt – 1-1/8" Bore	5200-452-029	
	6 Volt – 1-1/4" Bore	5200-452-032	
	90 Volt – 1-1/4" Bore	5200-452-035	
1-1	Rotor		1
	3/4" Bore	5200-751-002	
	7/8" Bore	5200-751-003	
	15/16" Bore	5200-751-004	
	1" Bore	5200-751-005	
	1-1/8" Bore	5200-751-006	
	1-1/4" Bore	5200-751-007	
1-2	Field		1
	6 Volt	5200-451-002	
	24 Volt	5200-451-004	
	90 Volt	5200-451-005	
1-3	Terminal Accessory	5311-101-001	1
1-4	Ball Bearing	166-0110	1
1-5	Retainer Ring	748-0002	1
2	Armature	5230-111-002	2
3	Armature Hub		1
	3/4" Bore	5300-541-006	
	7/8" Bore	5300-541-007	
	15/16" Bore	5300-541-008	
	1" Bore	5300-541-009	
	1-1/8" Bore	5300-541-010	
	1-1/4" Bore	5300-541-011	

Item	Description	Part Number	Qty.
4A	Mounting Accessory - I.M.	5102-101-001	2
4B	Mounting Accessory - O.M.	5300-101-008	1
5A	Magnet - I.M.		1
	6 Volt	5300-631-002	
	24 Volt	5300-631-003	
	90 Volt	5300-631-005	
5A-1	Terminal Accessory	5311-101-001	1
5B	Magnet - O.M. - Offset		1
	90 Volt	5300-631-014	
5B-1	Terminal Accessory	5311-101-001	1
5C	Magnet - O.M. - Flush		1
	6 Volt	5300-631-009	
	24 Volt	5300-631-010	
	90 Volt	5300-631-011	
5C-1	Terminal Accessory	5311-101-001	1
6	Conduit Box	5200-101-010	2

How to Order:

1. Specify Bore Size for Item 1 and Item 3.
2. Specify Voltage for Item 1 and Item 5A, 5B or 5C.
3. Specify Inside Mounted for Item 5A and Outside Mounted (Offset) for Item 5B or Outside Mounted (Flush) for Item 5C.
4. See Controls Section.

Example:

SFPBC-500 Clutch Brake Coupling per I-25554 - 90 Volt, Inside Mounted, 1" Bore

These units, when used in conjunction with the correct Warner Electric conduit box, meet the standards of UL508 and are listed under guide card #NMTR, file #59164.

These units are CSA certified under file #LR11543.

Refer to Service Manual P-202.

Clutch/Brake Coupling

SFPBC-650

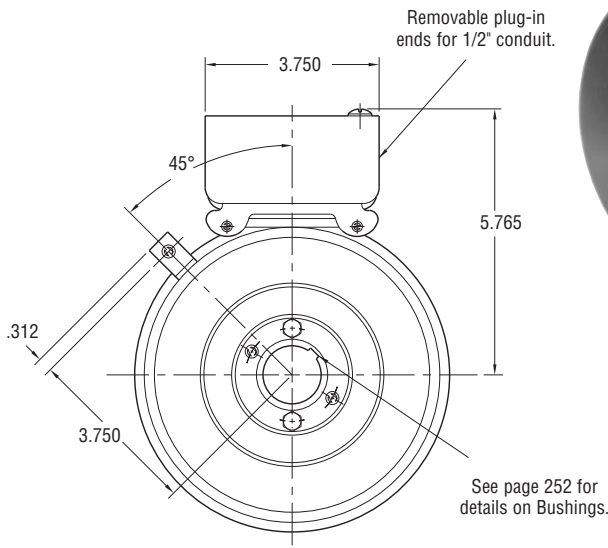

FIELD VIEW

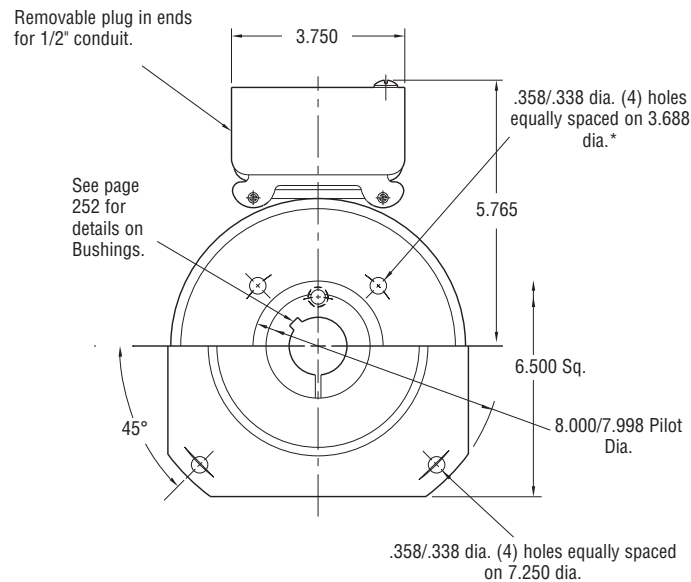

MAGNET VIEW
(Inside & Outside Mounted)

Customer Shall Maintain:

1. Squareness of brake mounting face with armature hub shaft within .006 T.I.R.
2. Concentricity of brake mounting pilot diameter with armature hub shaft within .010 T.I.R.
3. Concentricity of clutch magnet hub assembly shaft with armature hub shaft within .006 T.I.R.

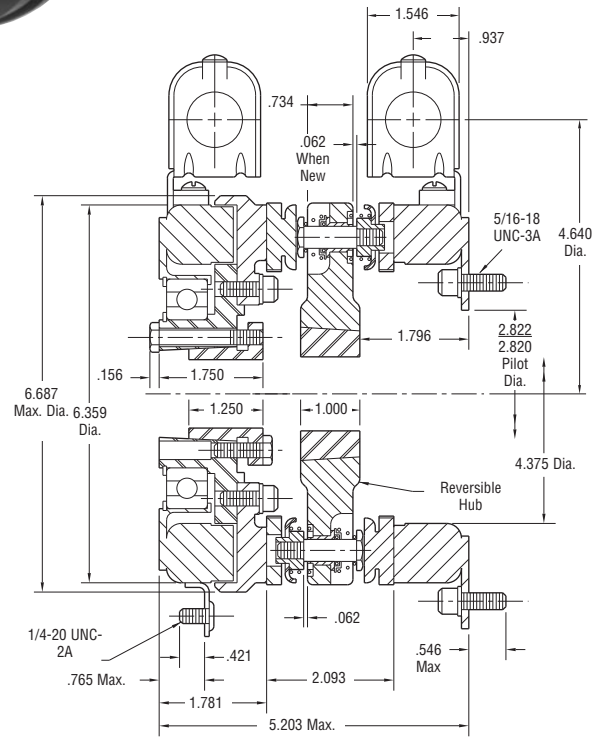

* Mounting holes are within .010 of true position relative to pilot diameter.

Shaft Size	.500 – 1.500
Static Torque Clutch	95 lb. ft.
Static Torque Brake	95 lb. ft.
Maximum Speed	3,600 rpm
Standard Voltage	D.C. 6, 24, 90

All dimensions are nominal unless otherwise noted.

Information on inertia and weights begins on page 239. Coil data is on pages 250 and 251.



Drawing I-25751

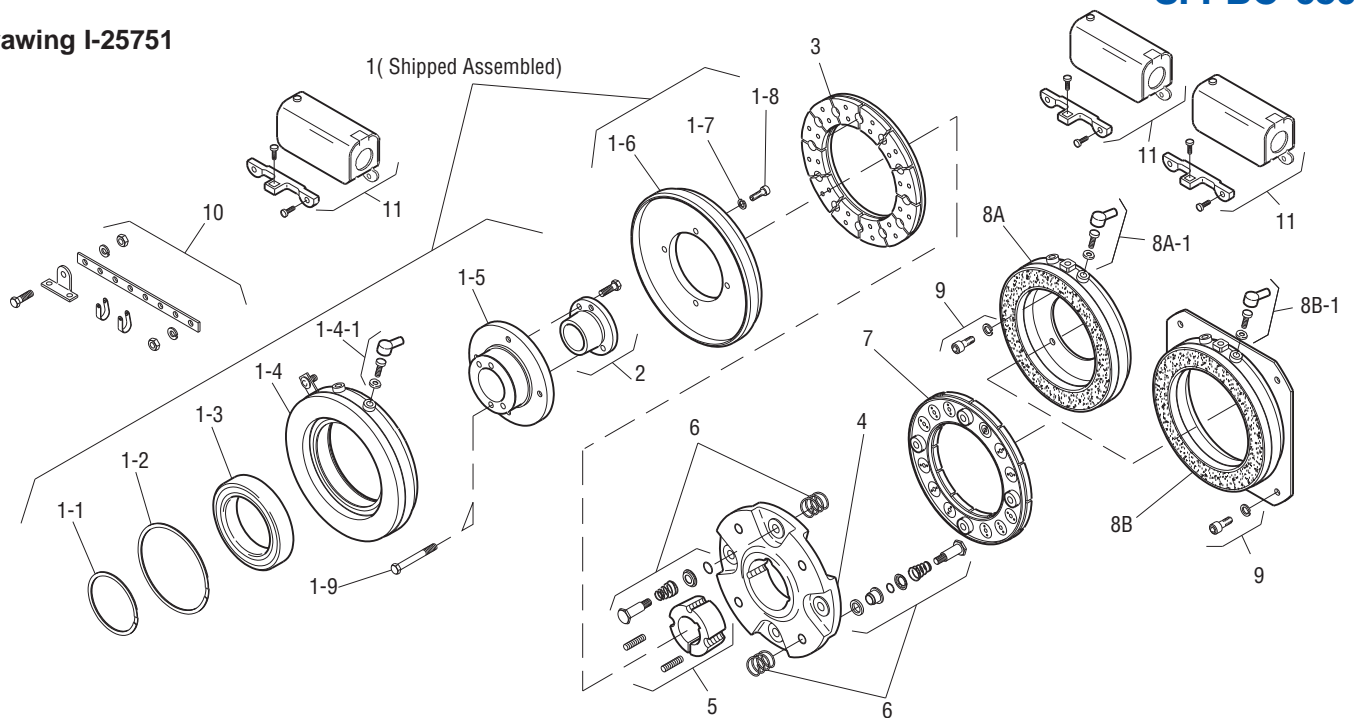

Item	Description	Part Number	Qty.
1	Field & Rotor Assembly		1
	6 Volt	5207-452-002	
	24 Volt	5207-452-005	
	90 Volt	5207-452-004	
1-1	Retainer Ring External	748-0004	1
1-2	Retainer Ring Internal	748-0104	1
1-3	Ball Bearing	166-0104	1
1-4	Field Assembly		1
	6 Volt	5281-451-002	
	24 Volt	5281-451-004	
	90 Volt	5281-451-005	
1-4-1	Terminal Accessory	5311-101-001	3
1-5	Rotor Hub	540-0614	1
1-6	Rotor Assembly	5281-751-001	1
1-7	Lockwasher	950-0355	4
1-8	Capscrew	797-0083	4
1-9	Reverse Mounting Accessory	5201-101-005	1
2	Bushing*		1
	1/2" to 1-1/2" Bore	180-0002 to 180-0018	
3	Armature Clutch	5281-111-002	1
4	Armature Hub	5207-541-002	1
5	Bushing*		
	1/2" to 1-5/8" Bore	180-0326 to 180-0344	1
6	Autogap Accessory	5181-101-010	8
7	Armature - Brake	5281-111-002	1
8A	Magnet - Inside Mounted		1
	6 Volt	5369-631-003	
	24 Volt	5369-631-006	
	90 Volt	5369-631-005	

Item	Description	Part Number	Qty.
8A-1	Terminal Accessory	5311-101-001	2
8B	Magnet - Outside Mounted		1
	6 Volt	5369-631-009	
	24 Volt	5369-631-012	
	90 Volt	5369-631-011	
8B-1	Terminal Accessory	5311-101-001	2
9	Mounting Accessory	5321-101-002	1
†10	Torque Arm Accessory	5207-101-003	1
11	Conduit Box	5200-101-010	3

How to Order:

1. Specify Voltage for Item 1 and Item 8.
2. Specify Bore Size for Item 2 and Item 5.
3. Specify Inside Mounted for Item 8A and Outside Mounted for Item 8B.
4. See Controls Section.

Example:

SFPBC-650 per I-25751 - 90 Volt, 1" Bore

These units, when used in conjunction with the correct Warner Electric conduit box, meet the standards of UL508 and are listed under guide card #NMTR, file #59164. These units are CSA certified under file #LR11543

*See page 252 for specific part numbers.

Refer to Service Manual P-202.

†Optional – not included in price.